



OSISKO DEVELOPMENT

A PREMIER NORTH AMERICAN GOLD COMPANY



Our New Acquisition –

TINTIC PROJECT

EAST TINTIC MINING DISTRICT
UTAH COUNTY, UTAH, USA

Cautionary Statements Regarding Forward Looking Information



FORWARD LOOKING INFORMATION

This presentation (this "**Presentation**") contains forward-looking information and forward-looking statements (together, "**forward-looking statements**") within the meaning of applicable Canadian securities laws and the *United States Private Securities Litigation Reform Act of 1995*. All statements, other than statements of historical fact, are forward-looking statements and are based on expectations, estimates and projections as at the date of this Presentation. Any statement that involves discussions with respect to predictions, expectations, beliefs, plans, projections, objectives, assumptions, future events or performance (often but not always using phrases such as "expects", or "does not expect", "is expected", "anticipates" or "does not anticipate", "plans", "budget", "scheduled", "forecasts", "estimates", "believes" or "intends" or variations of such words and phrases or stating that certain actions, events or results "may" or "could", "would", "might" or "will" be taken to occur or be achieved) are not statements of historical fact and may be forward-looking statements.

In this Presentation, forward-looking statements relate, among other things: the prospects, projections and success of Osisko Development Corp. ("**Osisko Development**" or "**ODV**"); the ability of Osisko Development to identify mineral resources at certain of our properties; our ability to expand mineral resources beyond current mineral resource estimates; the utility of the existing infrastructure at the Trixie test mine ("Trixie"); the utility of historic data in respect of Trixie and Bergin; opportunities for growth of mineral projects; the ability to adapt to changes in gold prices; estimates of costs, estimates of planned exploration and development expenditures; estimates of mine development and construction costs; the ability of Osisko Development to obtain further capital on reasonable terms; Osisko Development being well-positioned as a gold development company in Canada, USA and Mexico; indicative valuations; expected investor returns; mineral inventory; and estimates of gold prices. All forward-looking statements entail various risks and uncertainties that are based on current expectations and actual results may differ materially from those contained in such information.

Although Osisko Development believes the expectations expressed in such forward-looking statements are based on reasonable assumptions, such statements involve known and unknown risks, uncertainties and other factors and are not guarantees of future performance and actual results may accordingly differ materially from those in forward-looking statements. These uncertainties and risks include, but are not limited to, risks relating to the ability of exploration activities (including drill results) to accurately predict mineralization; the ability to realize upon geological modelling; the ability of Osisko Development to complete further exploration activities, including drilling; property interests in the assets of Osisko Development; the ability of the results of exploration activities; risks relating to mining activities; fluctuations in spot and forward prices of gold, silver, base metals or certain other commodities; fluctuations in currency markets (such as the Canadian dollar to United States dollar exchange rate); change in international, national and local government, legislation, taxation, controls, regulations and political or economic developments; risks and hazards associated with the business of mineral exploration, development and mining (including environmental hazards, industrial accidents, unusual or unexpected formations pressures, cave-ins and flooding); inability to obtain adequate insurance to cover risks and hazards; the presence of laws and regulations that may impose restrictions on mining; employee relations; relationships with and claims by local communities and indigenous populations; availability of increasing costs associated with mining inputs and labour; the speculative nature of mineral exploration and development (including the risks of obtaining necessary licenses, permits and approvals from government authorities); and title to properties. However, there can be no assurance that forward-looking statements will prove to be accurate, as actual results and future events could differ materially from those anticipated in such statements. Investors are cautioned that forward-looking statements are not guarantees of future performance. Osisko Development cannot assure investors that actual results will be consistent with these forward-looking statements and investors should not place undue reliance on forward-looking statements due to the inherent uncertainty therein.

For additional information with respect to these and other factors and assumptions underlying the forward-looking statements made herein concerning Osisko Development, please refer to the public disclosure record of Osisko Development, including the restated annual information form of Osisko Development for the year ended December 31, 2021 as amended, and the most recent annual and interim financial statements and related restated management's discussion and analysis of Osisko Development, which are available on SEDAR under Osisko Development's issuer profile and on the U.S. Securities Exchange Commission's EDGAR website (www.sec.gov). The forward-looking statements set forth herein concerning Osisko Development reflect management's expectations as at the date of this document and are subject to change after such date. Osisko Development disclaims any intention or obligation to update or revise any forward-looking statements, whether as a result of new information, future events or otherwise, other than as required by law.

This Presentation does not constitute an offer to sell or a solicitation of an offer to buy any securities in the United States or any other jurisdiction. No securities may be offered or sold in the United States or in any other jurisdiction in which such offer or sale would be unlawful prior to registration under the U.S. Securities Act of 1933 or an exemption therefrom or qualification under the securities laws of such other jurisdiction or an exemption therefrom.

Unless otherwise noted, this Presentation has been prepared based on information available as of June 10, 2022. All currency references are to Canadian dollars, unless specified otherwise.

Cautionary Statement Regarding Technical Information



HISTORIC RESOURCES

This Presentation references historic information in relation to the Burgin Mine, previously operated by Kennecott until 1978, and its potential for a significant silver-lead-zinc-gold deposit. A 2011 PEA included the historic resource presented herein. Osisko Development believes that the historic resource continues to be relevant and reliable as an indication of the potential of the Burgin Mine. Further exploration work including drilling will be required to upgrade the historic resource to current. Osisko Development cautions sufficient work has not been done to classify the historic resources as current resources and Osisko Development is not treating the historic resources as a current resource.

TINTIC TECHNICAL REPORT

The scientific and technical information in this Presentation relating to the Tintic Project is supported by the technical report entitled "Technical Report on the Tintic Project" dated June 10, 2022 (with an effective date of June 7, 2022) (the "Tintic Technical Report"). The author of the Tintic Technical Report is a "qualified person" within the meaning of NI 43-101 and considered to be "independent" of Osisko Development for purposes of Section 1.5 of NI 43-101. For further information reference should be made to the full text of the Tintic Technical Report, which is available electronically on SEDAR (www.sedar.com) under Osisko Development's issuer profile.

QUALIFIED PERSONS

Maggie Layman, P.Geol, Vice President Exploration of Osisko Development, and Mr. François Vézina, P.Eng., MBA, Senior Vice President, Project Development, Technical Services and Environment of Osisko Development Corp., each of whom is a "qualified person" for purposes of NI 43-101, have reviewed and approved the scientific and technical information in this Presentation.

CAUTION REGARDING CURRENT PRODUCTION

The Company cautions that the decision to commence production at Trixie in the form of small scale underground mining and batch vat leaching without the benefit of a feasibility study, or reported mineral resources or mineral reserves, demonstrating economic and technical viability, and, as a result there may be increased uncertainty of achieving any particular level of recovery of material or the cost of such recovery. The Company cautions that historically, such projects have a much higher risk of economic and technical failure. There is no guarantee that production will continue as anticipated or at all or that anticipated production costs will be achieved. The failure to continue production may have a material adverse impact on the Company's ability to generate revenue and cash flow to fund operations. Failure to achieve the anticipated production costs may have a material adverse impact on the Company's cash flow and potential profitability. In continuing current operations at Trixie after closing, the Company will not be basing its decision to continue such operations on a feasibility study, or reported mineral resources or mineral reserves demonstrating economic and technical viability. The Company cautions that mining at Trixie could be suspended at any time.

CAUTIONARY NOTE TO U.S. INVESTORS REGARDING MINERAL RESERVE AND MINERAL RESOURCE ESTIMATES

Osisko Development is subject to the reporting requirements of the applicable Canadian securities laws, and as a result, reports its mineral resources and reserves according to Canadian standards. Canadian reporting requirements for disclosure of mineral properties are governed by NI 43-101. The definitions of NI 43-101 are adopted from those given by the Canadian Institute of Mining, Metallurgy and Petroleum ("CIM"). U.S. reporting requirements are governed by the Industry Guide 7 ("Guide 7") of the Security and Exchange Commission ("SEC"). This presentation includes estimates of mineral reserves and mineral resources reported in accordance with NI 43-101. These reporting standards have similar goals in terms of conveying an appropriate level of confidence in the disclosures being reported, but embody different approaches and definitions. For example, under Guide 7, mineralization may not be classified as a "reserve" unless the determination has been made that the mineralization could be economically and legally produced or extracted at the time the reserve determination is made. Consequently, the definitions of "Proven Mineral Reserves" and "Probable Mineral Reserves" under CIM standards differ in certain respects from the standards of the SEC. Osisko Development also reports estimates of "mineral resources" in accordance with NI 43-101. While the terms "Mineral Resource," "Measured Mineral Resource," "Indicated Mineral Resource" and "Inferred Mineral Resource" are recognized by NI 43-101, they are not defined terms under standards of the SEC and, generally, U.S. companies are not permitted to report estimates of mineral resources of any category in documents filed with the SEC. As such, certain information contained in this presentation concerning descriptions of mineralization and estimates of mineral reserves and mineral resources under Canadian standards is not comparable to similar information made public by United States companies subject to the reporting and disclosure requirements of the SEC. Readers are cautioned not to assume that all or any part of measured mineral resources or indicated mineral resource exists, or is economically or legally mineable. Further, an inferred mineral resource has a great amount of uncertainty as to its existence and as to its economic and legal feasibility, and a reader cannot assume that all or any part of an inferred mineral resource will ever be upgraded to a higher category. Under Canadian rules, estimates of inferred mineral resources may not form the basis of feasibility or other economic studies.



Location, Lands, Assets and Infrastructure

Tintic Project Location



- Located 40 mi (64km) SW of Provo and 60 mi (95km) S of Salt Lake City, UT in Utah County
- Full road access via Interstate 15 and US 6
- Main office located at the Burgin mine site, 1.5 mi (2.5 km) NE of the Trixie mine
- Permitted, gold producing operation located in Utah's Tintic mining district
- 14,200 acres (5747 ha) patented claims
- 2,800 acres (1133 ha) of leased ground
- 23 past producing mines

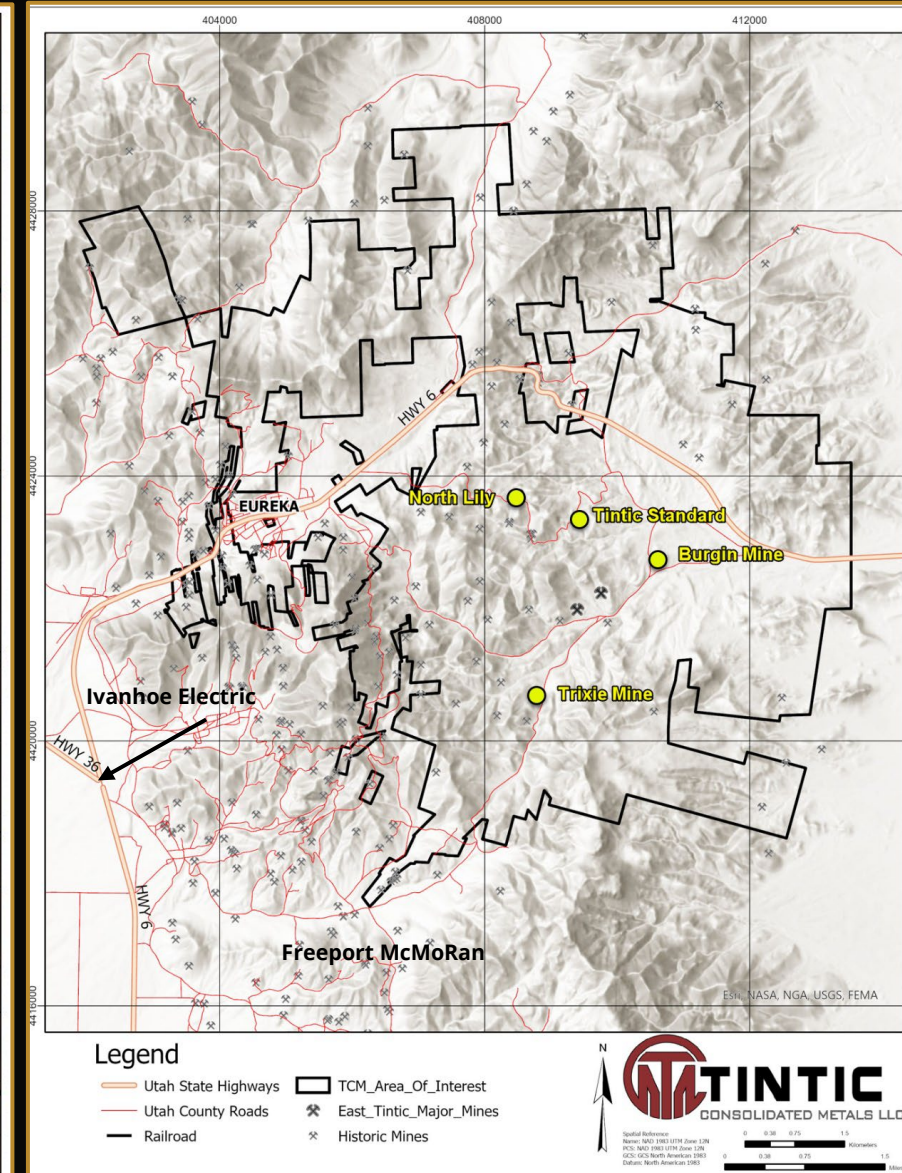
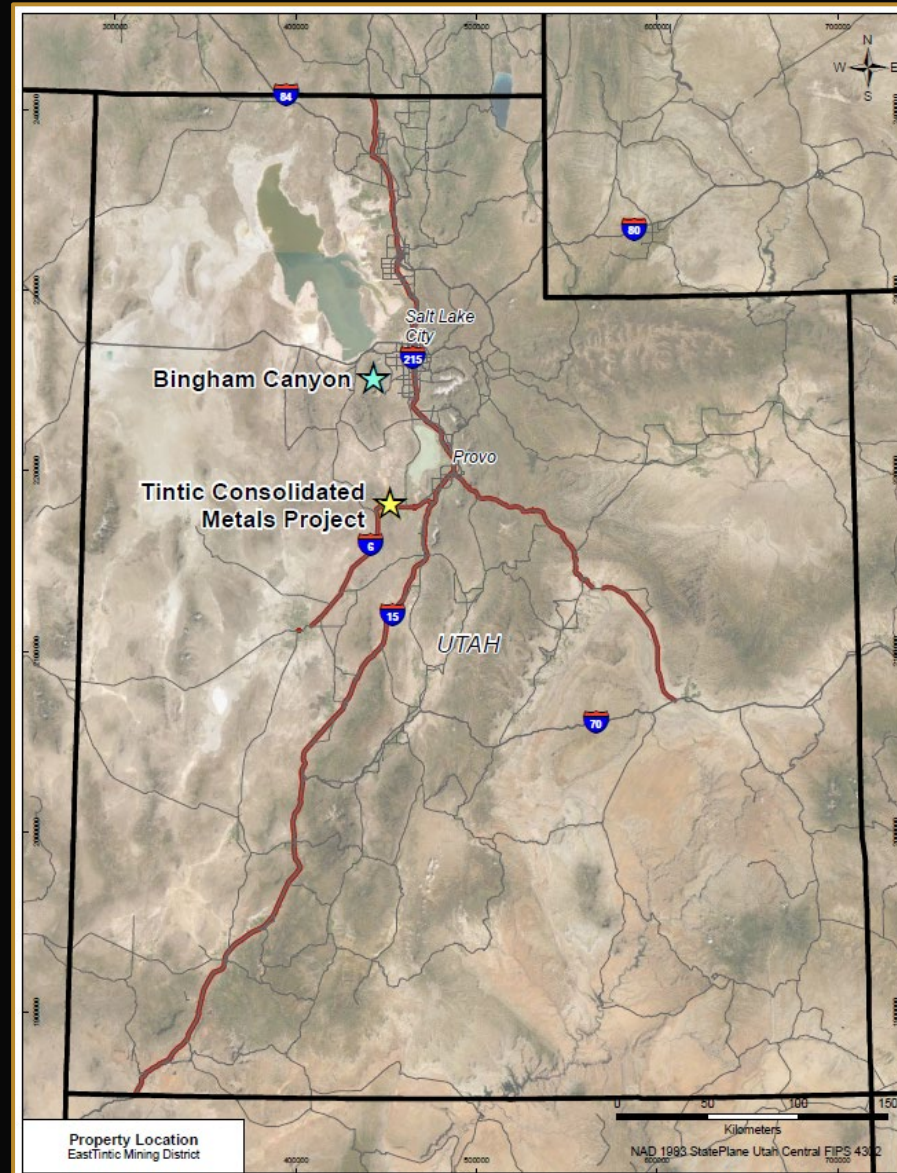

Tintic Project Permitting



	Large Mine Operations Permit	Exploration Permit
Permit Status	Currently operating under the 2017 Large Mine Operation (LMO)	Completed and approved
Permit Area and Bonds	231 permit acres, 73.9 acres (30 ha) bonded, with bond (non- material)	
Permit Updates and Allowances	2 nd draft of new LMO has been submitted to Department of Oil, Gas and Mining (DOG M) for final approval, and already responded to one set of comments	8 acres of disturbance
	Permitting only considers surface disturbance and reclamation. Permitting does not consider ton per day (tpd)	27,200 ft. of surface drilling
	On-site Vat leaching and tailing storage is permitted with ability to expand	Access roads and decline portal

Tintic Project Assets



Asset Summary

OWNERSHIP	<ul style="list-style-type: none"> ➤ 100% Osisko Development Corp.
MINERAL ASSETS:	<ul style="list-style-type: none"> ➤ Trixie gold mine, underground production and exploration development ➤ Eureka Standard, Ajax, North Lily (Trixie satellite expansion) ➤ Burgin (historic PEA (2011) Cu, Zn, Pb historic resource) ➤ Cu-Mo-Au Porphyry Targets
LOCATION	<ul style="list-style-type: none"> ➤ Located in Central Utah, ~40 mi (64km) south of Provo ➤ 60 mi (95 km) south of Salt Lake City ➤ 45 mi (70 km) South of Bingham Mine and Smelter
LAND PACKAGE	<ul style="list-style-type: none"> ➤ 14,200 acres of patented mining claims ➤ Additional 2,800 acres of leased claims
CURRENT MINING	<ul style="list-style-type: none"> ➤ Trixie high grade underground Au, Ag mine reopened by Tintic in 2021 ➤ 2021 production of 16,563 t @ 1.7 oz/t for a total of 14,608 oz with Vat leaching processing ➤ Present capacity of ~35 tpd ➤ Vat Leaching Circuit at Burgin mine site
INFRASTRUCTURE	<ul style="list-style-type: none"> ➤ Public utility power sub-station on-site ➤ Sealed, paved road to access site, running through site ➤ Int'l airport (Salt Lake) 80 mi (130 km) by road away ➤ Project is fully serviced and supplied by nearby towns in Western US
PERMITTING	<ul style="list-style-type: none"> ➤ Mining and processing permits in place at Trixie

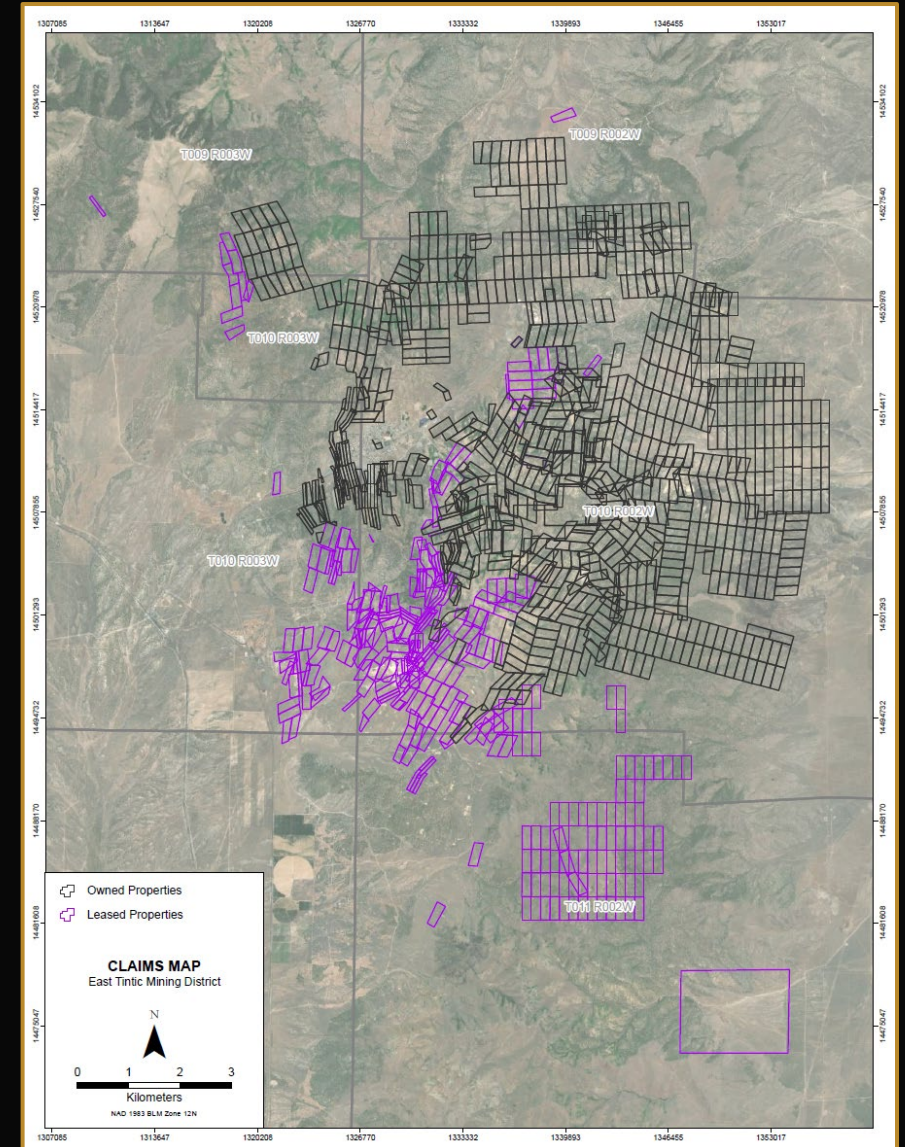

Site Resources and Infrastructure



- Underground workings, head frames and hoists
- Historical development to 1000 ft. + (~300 m+) to water table, opportunity to develop at depth
- Mining equipment
- Opportunity for water rights
- Grid power and paved roads
- Offices and maintenance building
- Assay laboratory
- Mill building housing cyanide Vat leaching system
- Vat tailings holding pad
- Significant land for additional tailings storage



Fire Assay Laboratory



- Current capacity of 91 samples per day for fire assay
- Expansion of sample preparation room in progress to increase capacity and improve repeatability of analysis
- Metallurgical test-work capabilities to support process monitoring and development



New baghouse installation



Prep Room Expansion



Fire assay fusions pouring



Atomic adsorption spectroscopy for process monitoring

Burgin Leach and Tailings Facilities



- **Four-tank cyanide Vat leaching system**
 - Processing ~35 tons per day at 80%+ recovery
 - Cash flow positive cyanide destruction with method of pre-discharge alkali chlorination of tailings yielding secondary leaching
- **60,000-ton capacity holding pad for tailings**
 - Operational as of May 17th, 2022
 - Can be re-permitted to operate as a heap leach pad as an option to ramp up processing



Near-Term Processing Growth



- Constructing a “Gold Room” to allow on-site stripping of carbon, and casting of doré for direct shipping to the refinery
- Grinding mill allows potential for increasing recovery to +90% via comminution
- Tailings facility permitted to allow dry stack of tailings
- Exploring opportunity to process surface stockpiles and low grade waste piles from historic mining operations for revenue generation

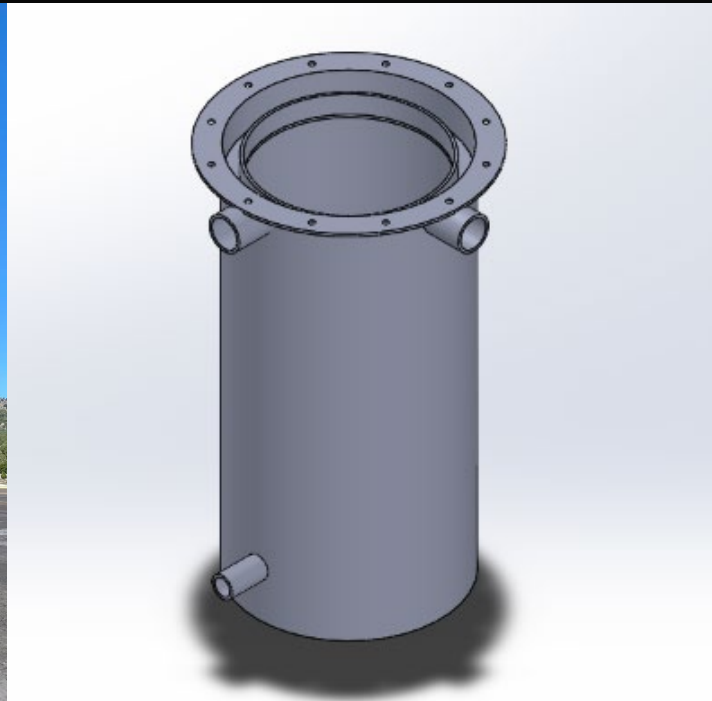



History

Early History of the Tintic Mining District

Year	Historic Highlights
1869	Polymetallic Ag, Au, Pb, Zn, Cu deposits discovered in Tintic Mining District (TMD)
1871	Eureka, Silver City, and Diamond City mining camps fully established
1899	First discovery within the East Tintic District (ETD); TMD recognized as one of the richest districts in the US
1906	E.J. Raddatz acquired Tintic Standard area to develop potential of Ophir Limestone
1916	E.J. Raddatz discovered the Pb-Ag Tintic Standard deposit
1921-1930	District production peaked with a total of 4.25 M tons over the decade
1927	Discovery of North Lily Deposit
1928	Discovery of Eureka Standard Deposit
1943	USGS explored blind mineralized bodies to support war effort in what would become the Burgin deposit

Early History of the Tintic Mining District



Major Historic Mineralized Material Bodies (red) of the Tintic Mining District, 1870s

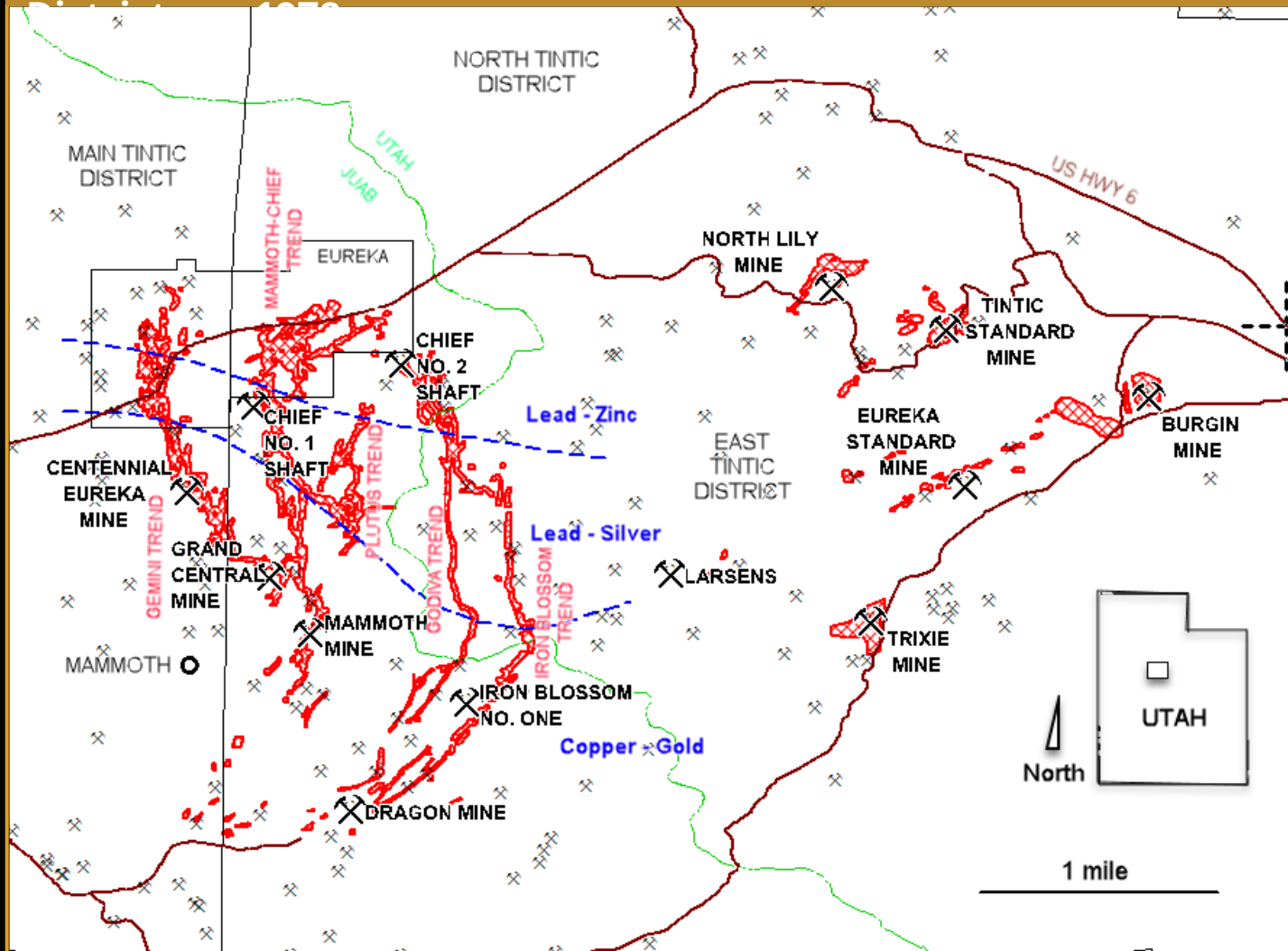

Tintic Mining District: Historic Production

Production for the Tintic Mining District: 1869-2002

Sub-District	Period	Material Treated (t ¹)	Gold (oz ²)	Silver (oz)	Copper (t)	Lead (t)	Zinc (t)
Main Tintic	1869-1993	13,813,942	2,166,841	207,687,987	109,866	644,750	69,258
East Tintic	1899-2002	5,982,827	658,224	75,871,239	17,759	507,981	178,545
SW Tintic	1869-1919	122,000	12,025	1,440,370	585	4,160	115
North Tintic	1902-1955	63,939	8	40,412	-	1,162,972	258,572
Total		19,982,708	2,837,098	285,039,918	128,210	1,162,972	258,572
		Short Tons	Gold (oz/t)	Silver (oz/t)	Copper (%)	Lead (%)	Zinc (%)
		19,982,708	0.14	14.26	0.64	5.82	1.29
Metal Prices Dec 2020			\$ 1,840	\$ 24	\$ 7,710	\$ 2,083	\$ 2,816
Value at Current Price			\$ 5,220,260,320	\$ 6,840,958,032	\$ 998,499,100	\$ 2,422,470,676	\$ 728,138,752
Total estimated value of historic production at 2020 Gold Price							\$16,200,326,880

1. Short tons
2. Troy ounces

History of the Trixie Deposit



Date	Historic Highlights
1956	Bear Creek Mining discovered strong Pb-Zn mineralization at the Trixie Mine
1968-1969	Au-Ag mineralization discovered at Trixie Mine along N-trending, steeply W-dipping 756 structure
1969-1992	Trixie material mined and shipped to Kennecott's Bingham Canyon smelter as silica flux.
1976	Trixie's 75-85 ore shoot discovered parallel to 756 structure
1980	Bear Creek Mining discovered the Survey (1050) vein at Trixie, as well as Au-Ag-Cu mineralization northward and down-dip of the 756 zone
1980-1992	Sunshine Mining re-started mining at Trixie and Burgin, expanding Survey Zone and connecting Trixie to the 1100 level of the Eureka Standard Mine
1993-1995	Chief Consolidated Mining Corporation (CCMC) mined and shipped low-grade smelter-flux, but became un-economic
2000-2002	CCMC developed low-tonnage Au-Ag resource associated with 75-85 zone
2002	CCMC ran the Trixie Mine producing high-grade Au concentrate from 75-85 zone, selling to Pinole Mining Company

Trixie Mine: Historic Production



Year	Tons	Au (oz/t)	Au (g/t)	Ag (oz/t)	Ag (g/t)	Au Total oz	Ag Total oz
Pre-1983	508,482	0.20	6.86	6.95	238.29	102,713	3,533,950
1983	1,736	0.30	10.29	4.80	164.57	516	8,333
1984	11,397	0.15	5.14	6.00	205.71	1,710	68,382
1985	25,538	0.25	8.57	3.49	119.66	6,487	89,128
1986	-	-	-	-	-	-	-
1987	2,527	0.25	8.57	4.69	160.80	627	11,852
1988	22,611	0.30	10.29	7.08	242.74	6,716	160,086
1989	28,343	0.32	10.97	7.13	244.46	9,070	230,429
1990	31,115	0.27	9.26	6.68	229.03	8,159	207,706
1991	40,608	0.18	6.17	4.96	170.06	7,486	201,418
1992	50,002	0.13	4.46	3.35	114.86	6,488	167,531
1993-1995 (dump/flux)	74,761	0.03	0.89	0.66	22.63	1,944	49,342
1995-2001	-	-	-	-	-	-	-
2002	11,120	0.66	22.73	2.39	81.94	7,373	26,577
Totals	808,240	0.196	6.72	5.85	200.57	158,323	4,726,505

Trixie Mine: Polymetallic Mineralization



3 Historic Mineralization Zones within the Trixie Vein System:

- 756 Ore Shoot:
 - Developed over 900 ft. (275m) strike and 1000 ft. (300 m) vertical
 - Open at depth
- 75-85 Ore Shoot:
 - Focus of 2001-2002 mining activity
 - Mined down to the 1200 ft. level
- Survey Vein
 - Mined by Kennecott in the 1980's
 - Extends for 3,400 ft. (1030 m) south of the main shaft and remains open to the south and at depth

Plan map of the major structural elements of the historic Trixie mine, and current exploration and mine development.

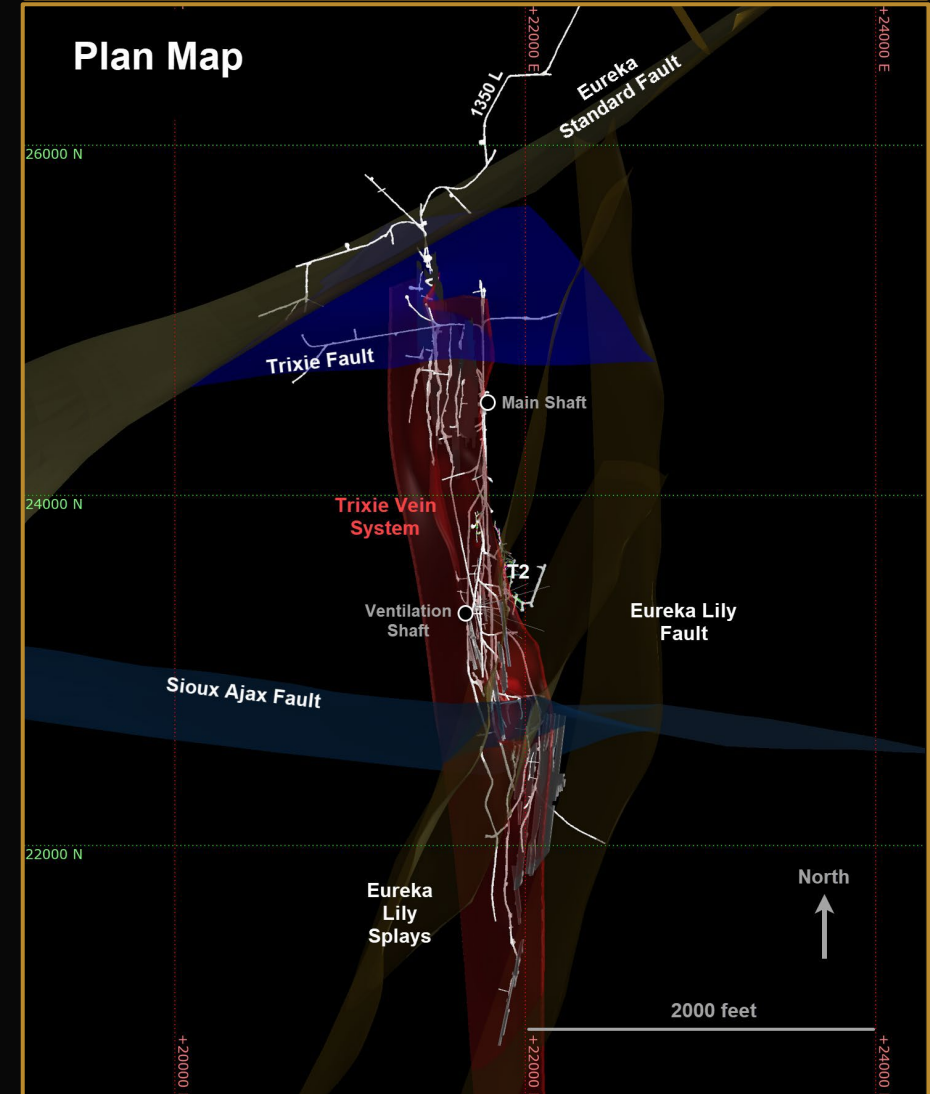

Trixie Mine: Modern Target Generation



Date	Historic Highlights
August 2019	Tintic Consolidated Metals (TCM) acquired the Trixie Mine and commenced rehabilitation of the mine and shaft
December 2019	TCM compiled historic Trixie data in a new 3D model which identified the footwall of the 610 stope as an important new target area, leading to the discovery of the T2 structure
June 2020	TCM completed refurbishment of 625 level
August 2020	TCM completed 5 diamond drillholes, with 3 holes confirming mineralization in the 610 footwall
September 2020	Discovery of the T2 structure and T2-T4 mineralization zone during exploration development
November 2020	First gold pour from TCM
April 2021	TCM recommenced underground drilling at T2 structure
June-August 2021	T2-T4 zone geologic modelling and mine design work for internal ramp and surface portal
September-October 2021	TCM constructed and commissioned the Burgin Processing Facility Vat Leaching Plant
December 2021	Ongoing exploration, delineation drilling, and mining of T2-T4 zone. TCM commenced permitting and survey work for the portal and underground decline from surface

Trixie Mine: Modern Target Generation



An oblique view of the new 3D model of the historic Trixie mine

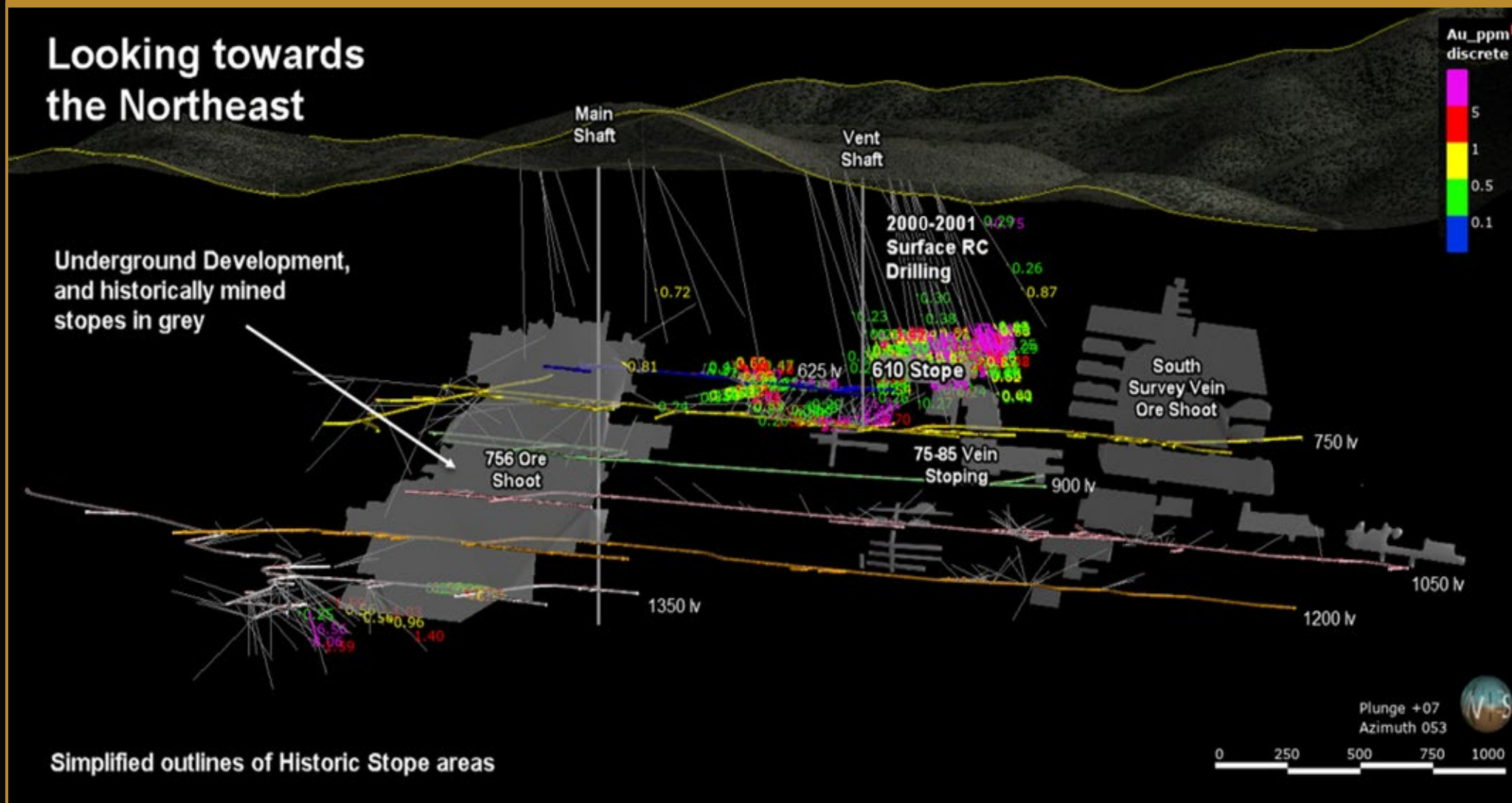

Trixie Mine: Modern Target Generation



Overview of the Trixie Mine historic datasets, including surface RC drilling colored by gold, dated 2019

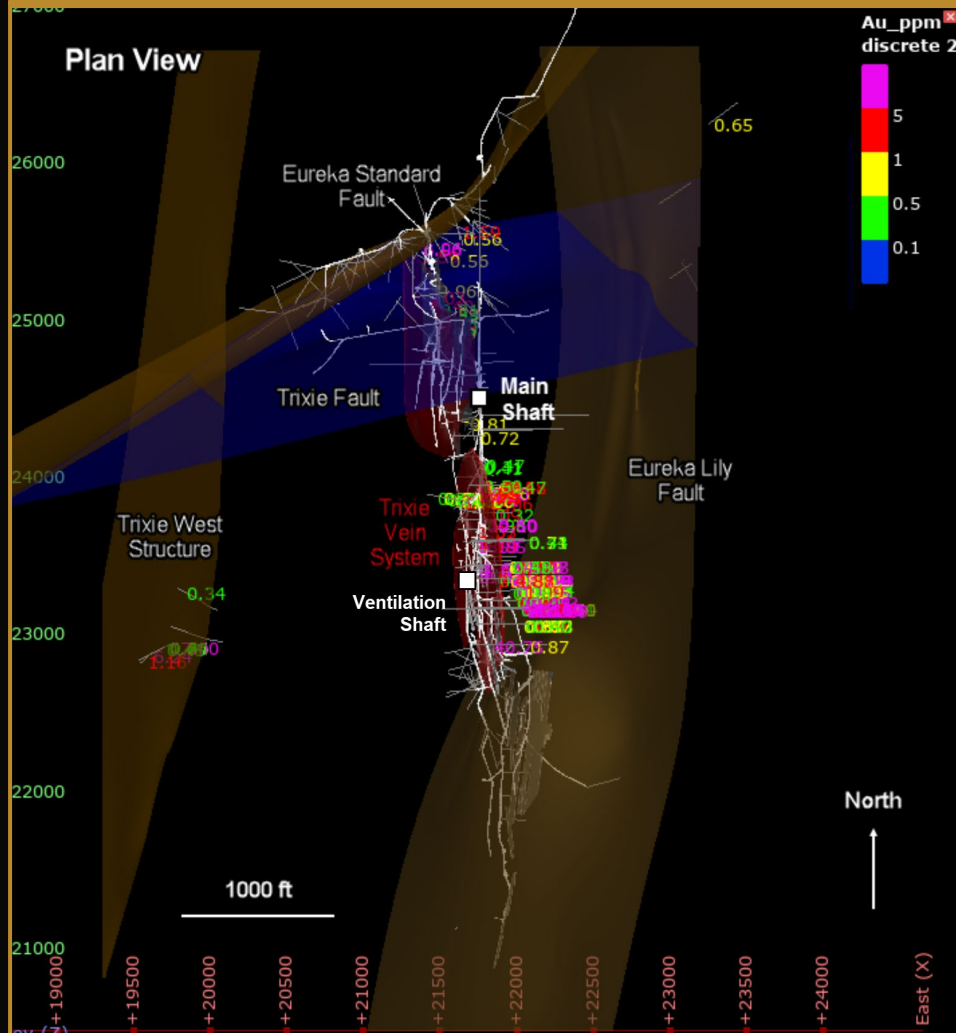

Overview map of the southern end of 625 level

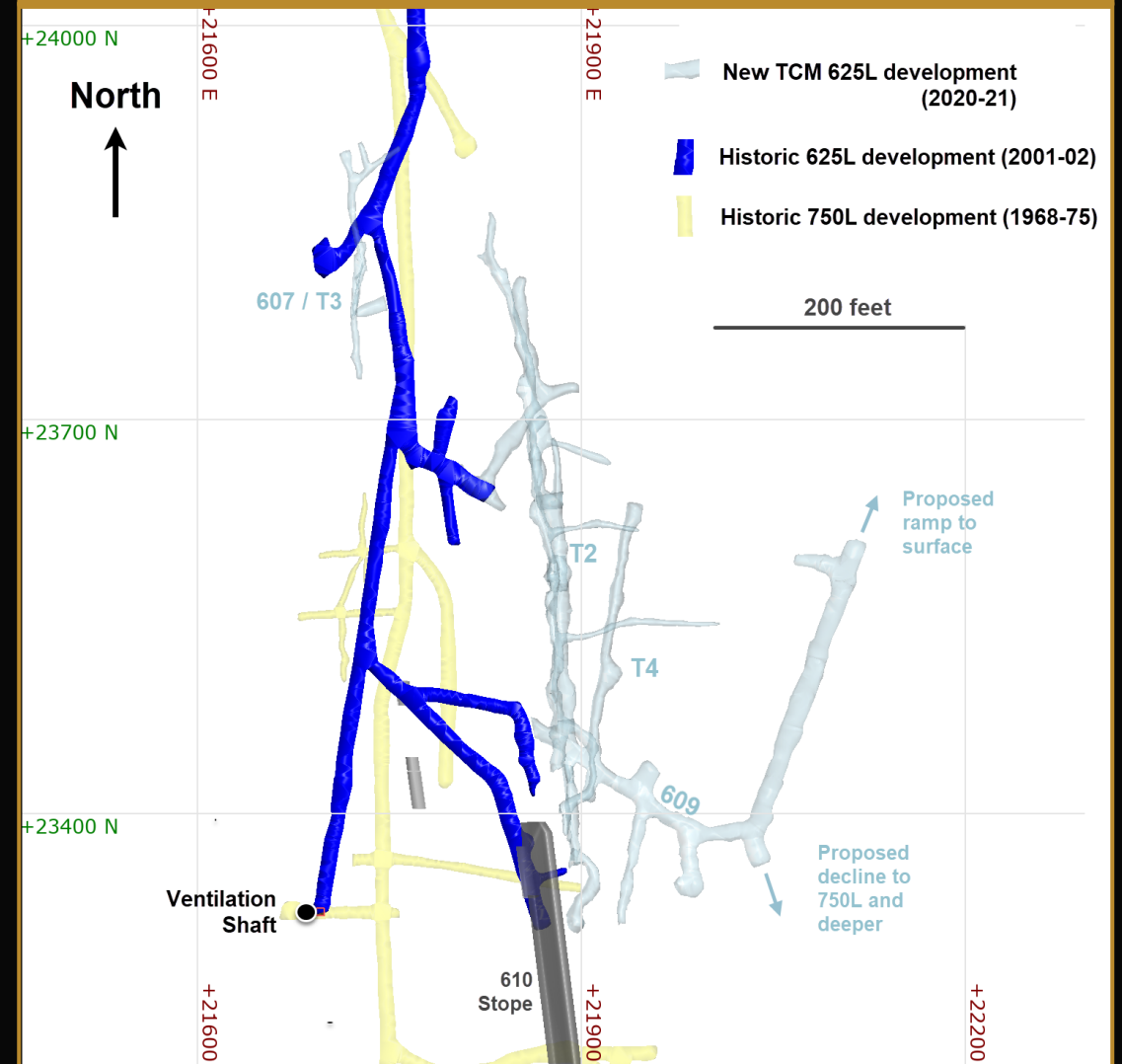

Trixie Mine: Modern Target Generation



An early mining face on the T2 structure

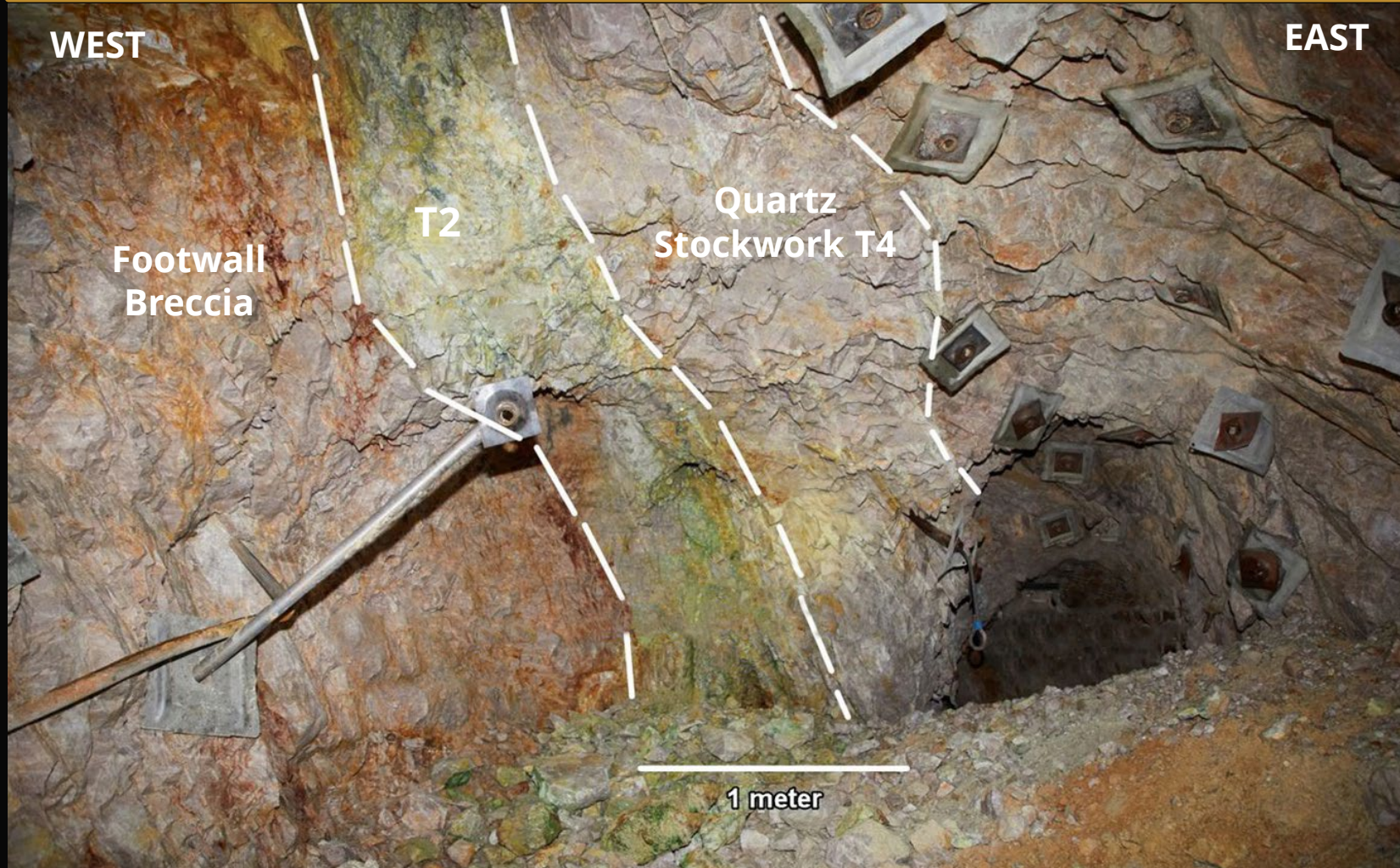



District Geology

Geology and Mineralization of the Greater Tintic District

District Geology



- TCM mineral claims cover the bulk of the East Tintic mining district as well as portions of the North Tintic, Main Tintic, and Southwest Tintic districts
- District geology can be summarized in four phases of geologic evolution
 1. Deposition of >10,000 ft. (3,000 m) Paleozoic platformal sequence atop rarely exposed Neoproterozoic basement
 2. Folding, faulting, uplift, and significant differential erosion of the Paleozoic sequence during Late Cretaceous Sevier Orogeny
 3. Eocene to Oligocene calc-alkaline magmatism resulting in:
 - Deposition of a latite flow and tuff dominant sequence of irregular thickness up to 5,000ft (1,500m) thick
 - Emplacement of monzonite to quartz-monzonite porphyry stocks, dikes, and sills from which mineralizing fluids and associated hydrothermal alteration across the district are sourced
 4. Miocene to recent Basin and Range extension and associated block faulting

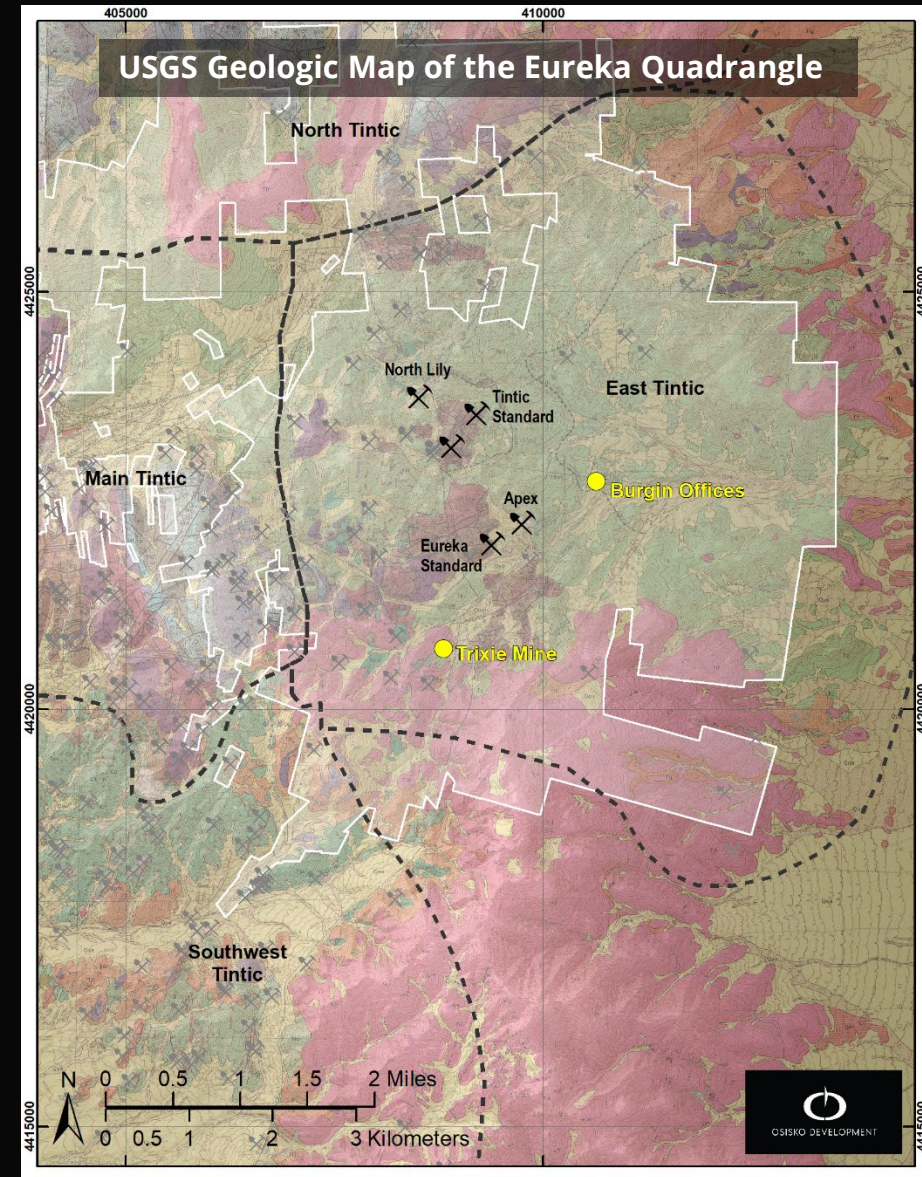

District Geology



- The significance of structural control on base and precious metal mineralization is especially pronounced within the East Tintic District
- Significant pre-mineralization structures of the East Tintic include
 - The north-trending East Tintic Anticline
 - The east-directed East Tintic and Tintic Standard thrust faults
 - A system of moderate to steeply dipping east-west to northeast-trending moderate to steeply northwest-dipping faults likely developed as strike-slip accommodation structures during late Sevier Orogeny
- Post-mineralization Basin and Range extension contributes to differential uplift of mineralized domains.

Structures, Intrusions, & Metal Domains of the Tintic

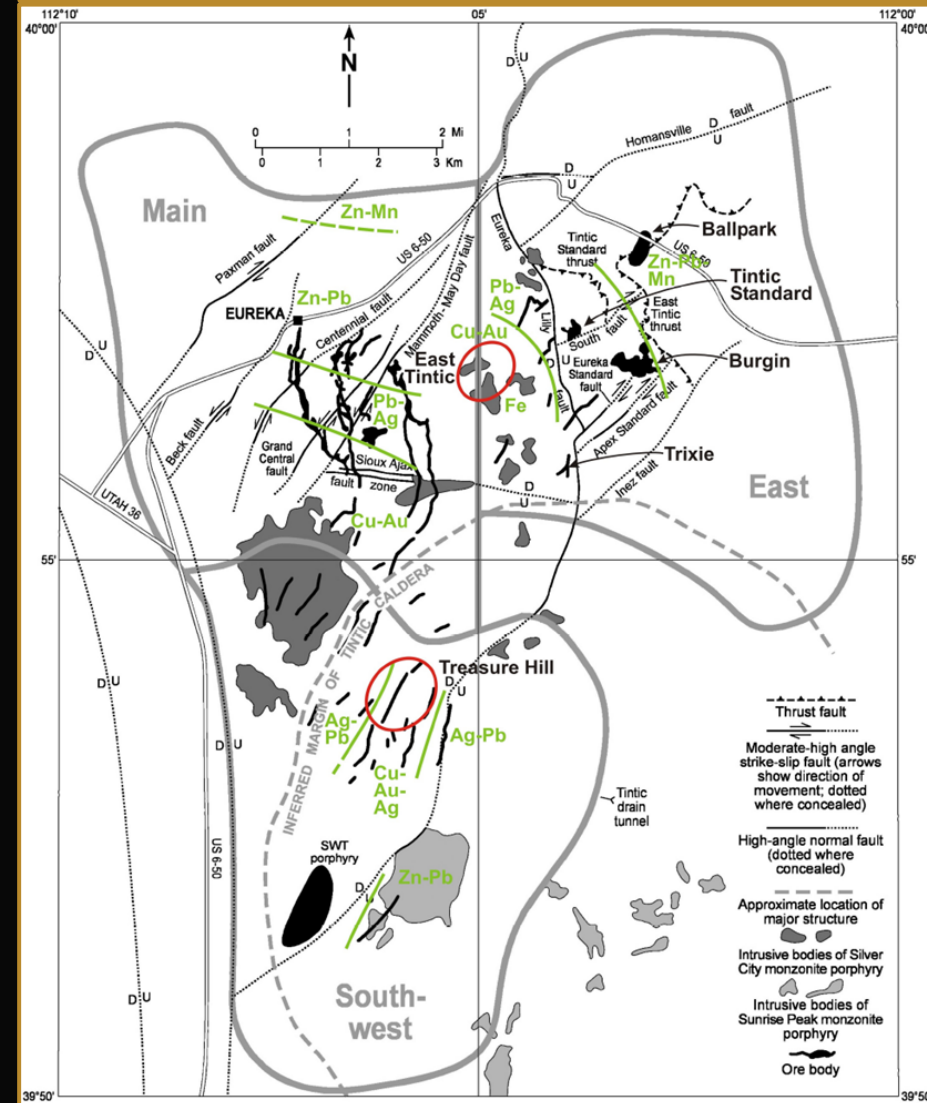

District Mineralization

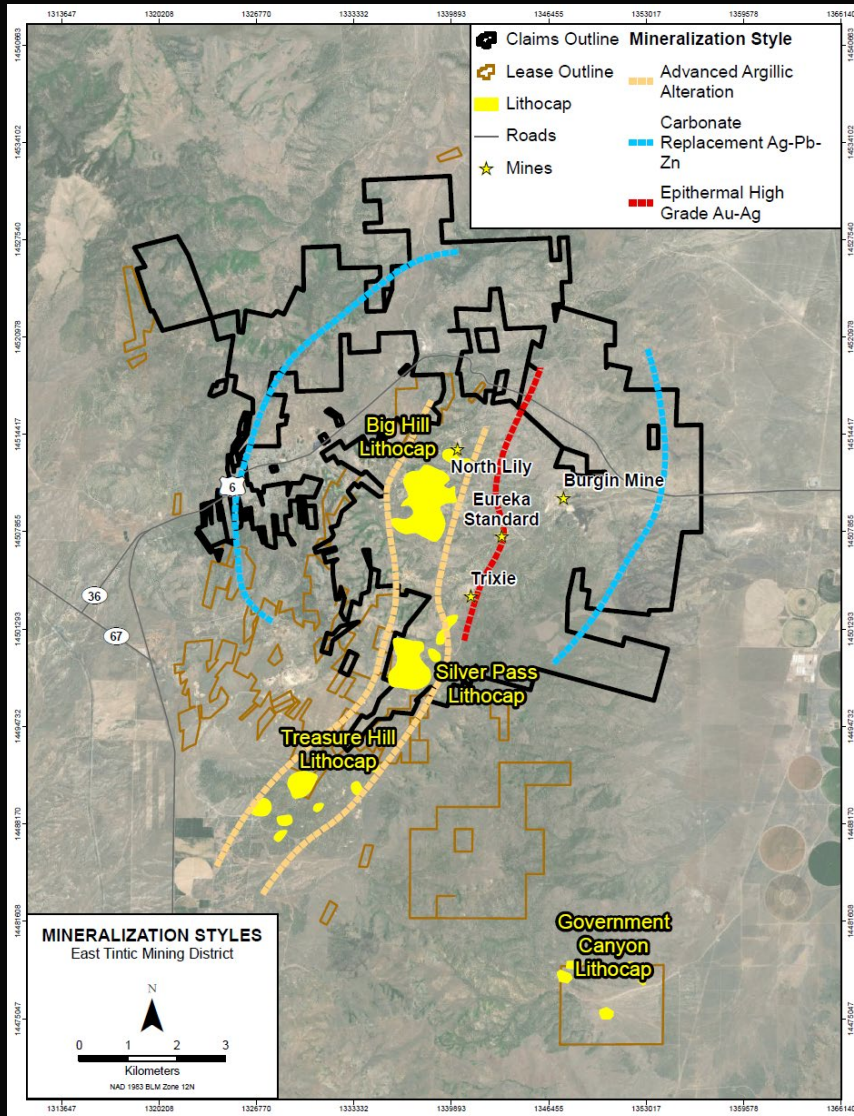

- CARBONATE REPLACEMENT Ag-Pb-Zn** Replacement of reactive limestone more distal from causative porphyry centers on the margins of district. Accounts for most historical production within Tintic, including at the Burgin, Tintic Standard, and North Lily mines.
- EPITHERMAL HIGH-GRADE Au-Ag** Developed with strong lithologic and structural control within the Lower Paleozoic Tintic Quartzite. Recent discovery of the high-grade T2 structure at the Trixie mine marks the southerly end of highly prospective 5km+ trend.
- PORPHYRY Cu-Ag POTENTIAL** Advanced argillic alteration in a NNE trend of remnant lithocaps (yellow) likely marks a lineament of porphyry centers at depth. Very limited Historic drill testing (8 holes) intersected low grade porphyry mineralization.

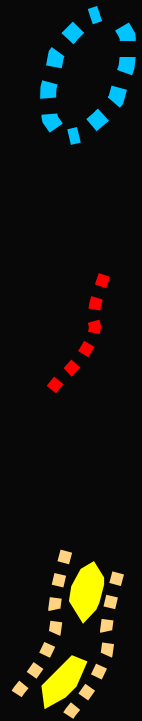

District Mineralization



Styles of mineralization and alteration present within the Tintic district qualify it as a classic porphyry-epithermal system with a high degree of rheologic and structural control on mineralization style and distribution.

District-scale Porphyry-Epithermal System Deposit Model

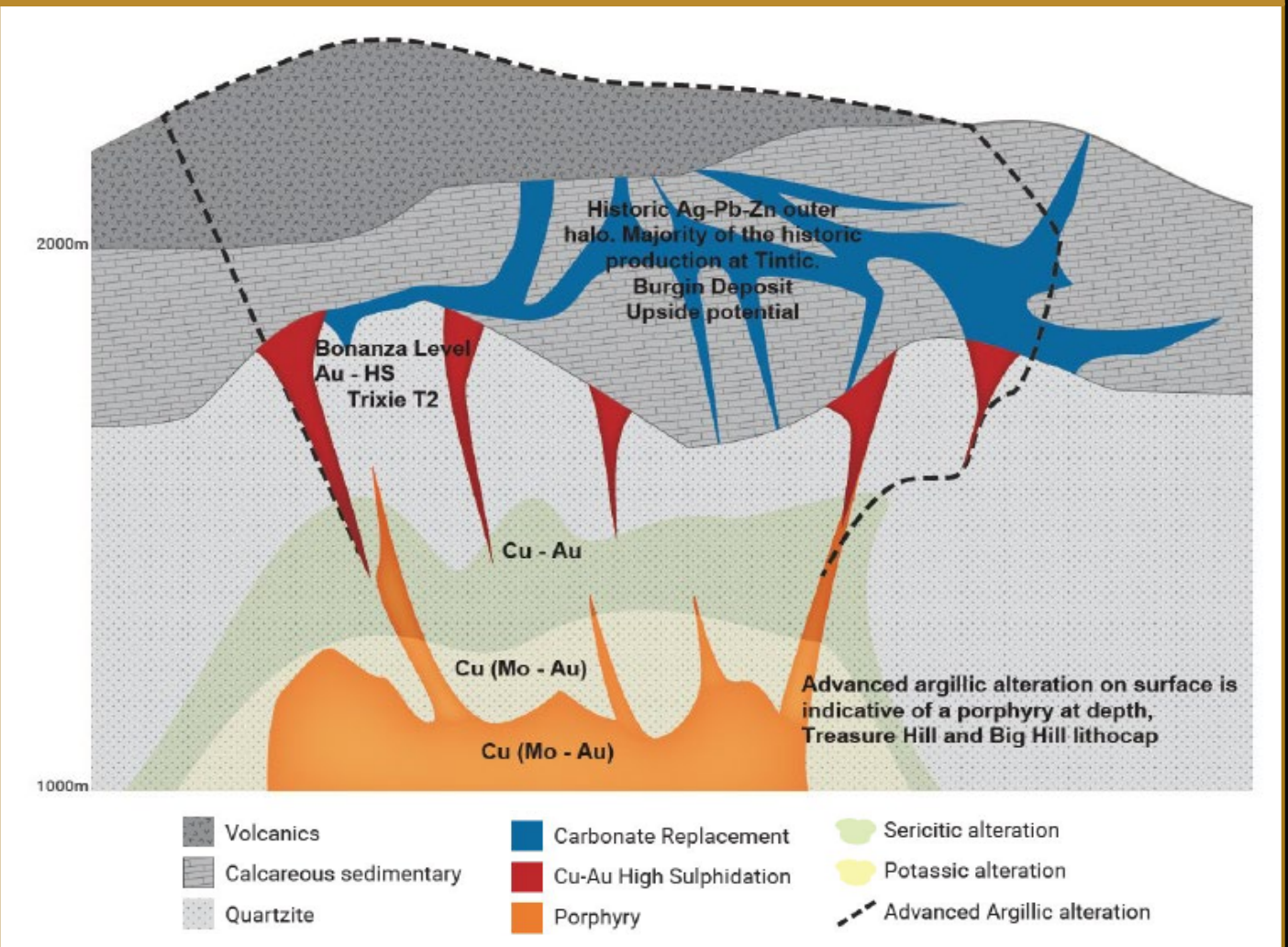



Trixie Mine Geology

Geology and Mineralization of the Trixie Mine

Trixie Mine Geology



- The Trixie Mine is situated proximal to the crest of the regional-scale East Tintic Anticline
- High-sulphidation epithermal mineralization structurally controlled and hosted within the brittle Tintic Quartzite
- Mineralization capped by impermeable shales of the Lower Ophir Formation
- Historic production along the N-S trending and steep to the west-dipping 75-85 structure
- Modern production focus within the 75-85 hanging-wall
- Along the N-S trending subvertical to the east-dipping T2 structure
- Within the T4 zone of high-density, smaller-scale T2 parallel structures.

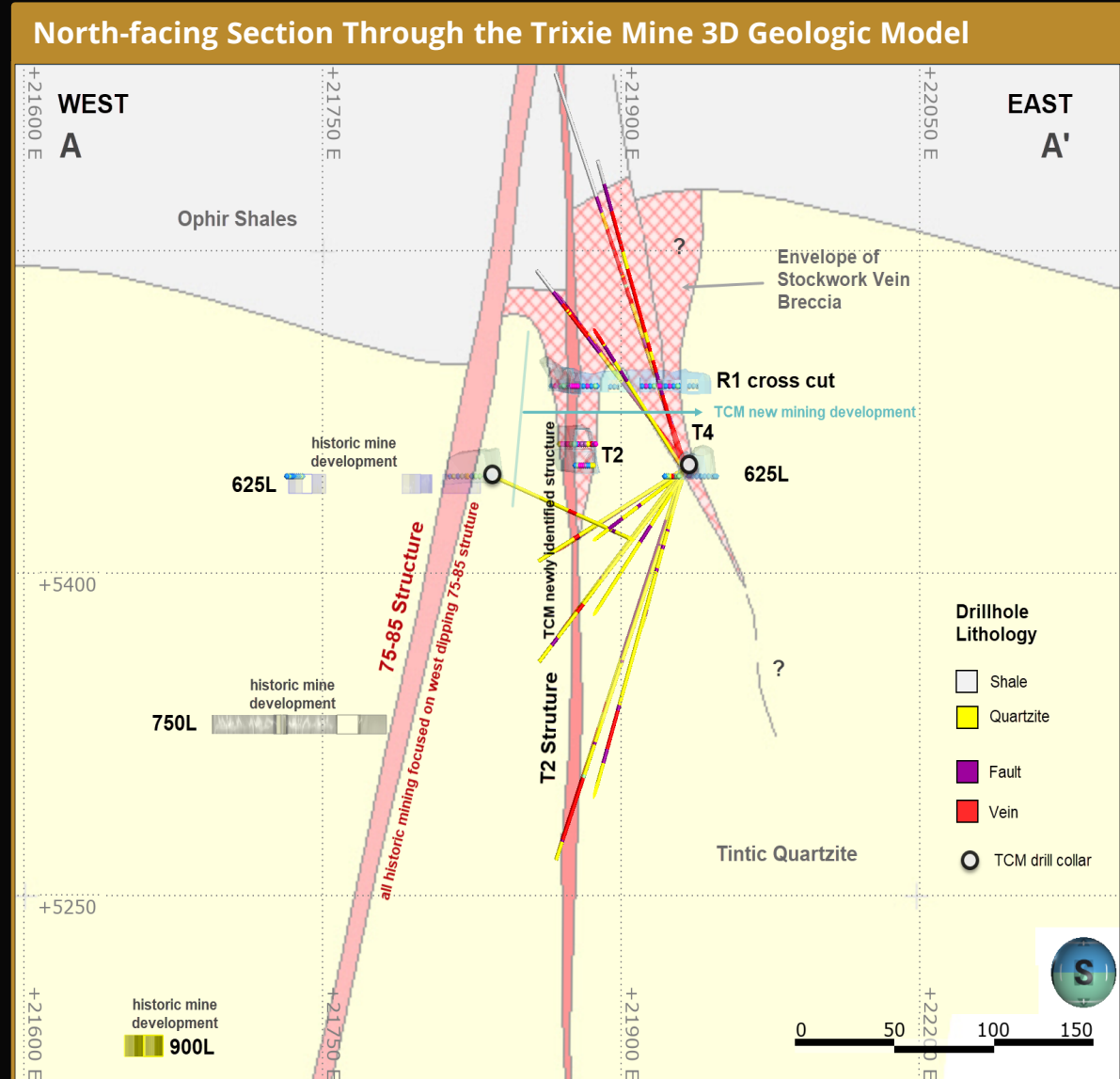

Trixie Mine Geology



- Main Au-mineralized material bodies at the Trixie mine plunge steeply northward at the its north end, and southward at its south end
- Consistent with mineralizing fluid utilization of the northeast-trending north-dipping Trixie Fault and east-west-trending locally south-dipping Sioux Ajax fault
- Basin and range normal reactivation of these pre-mineral structures gives potential for Trixie style-mineralization at greater depth along strike to the north and south

Modeled Structures and Development at the Trixie Mine

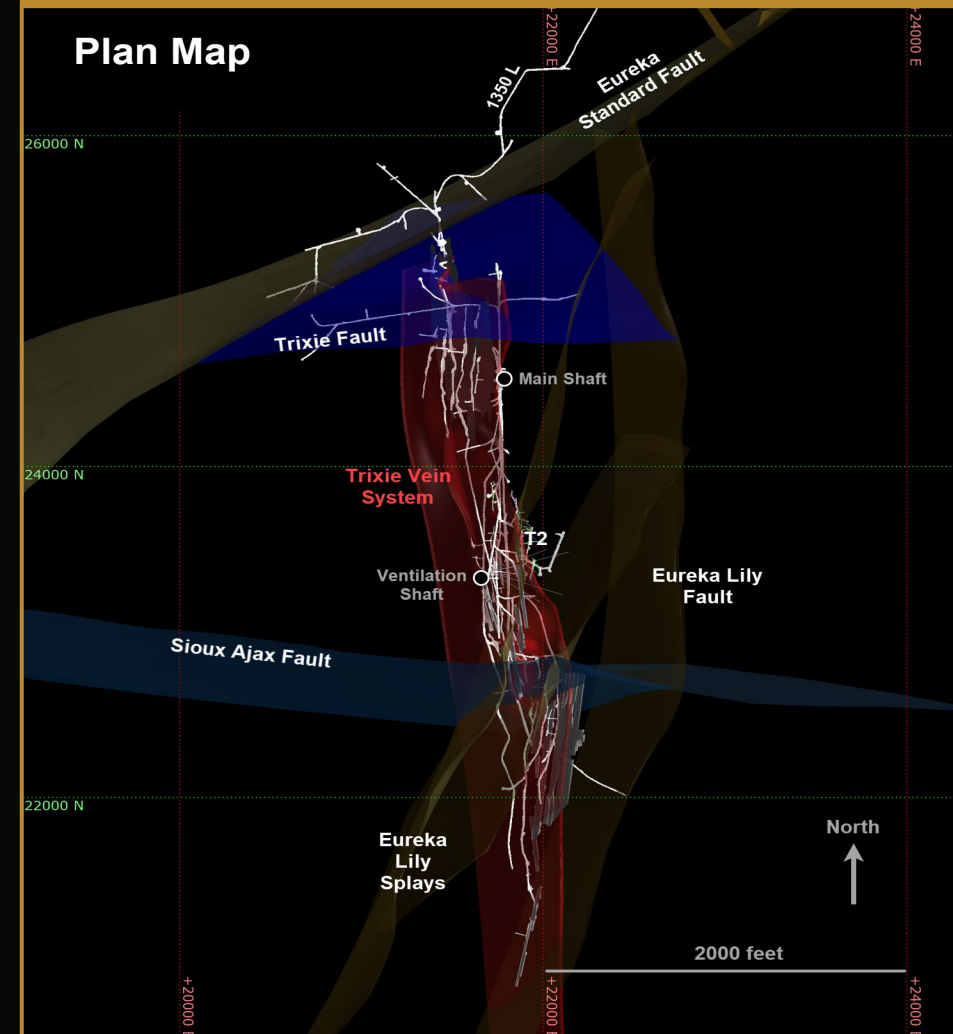

Trixie Mine Geology



West-Facing Geologic Long Section of the Trixie Mine

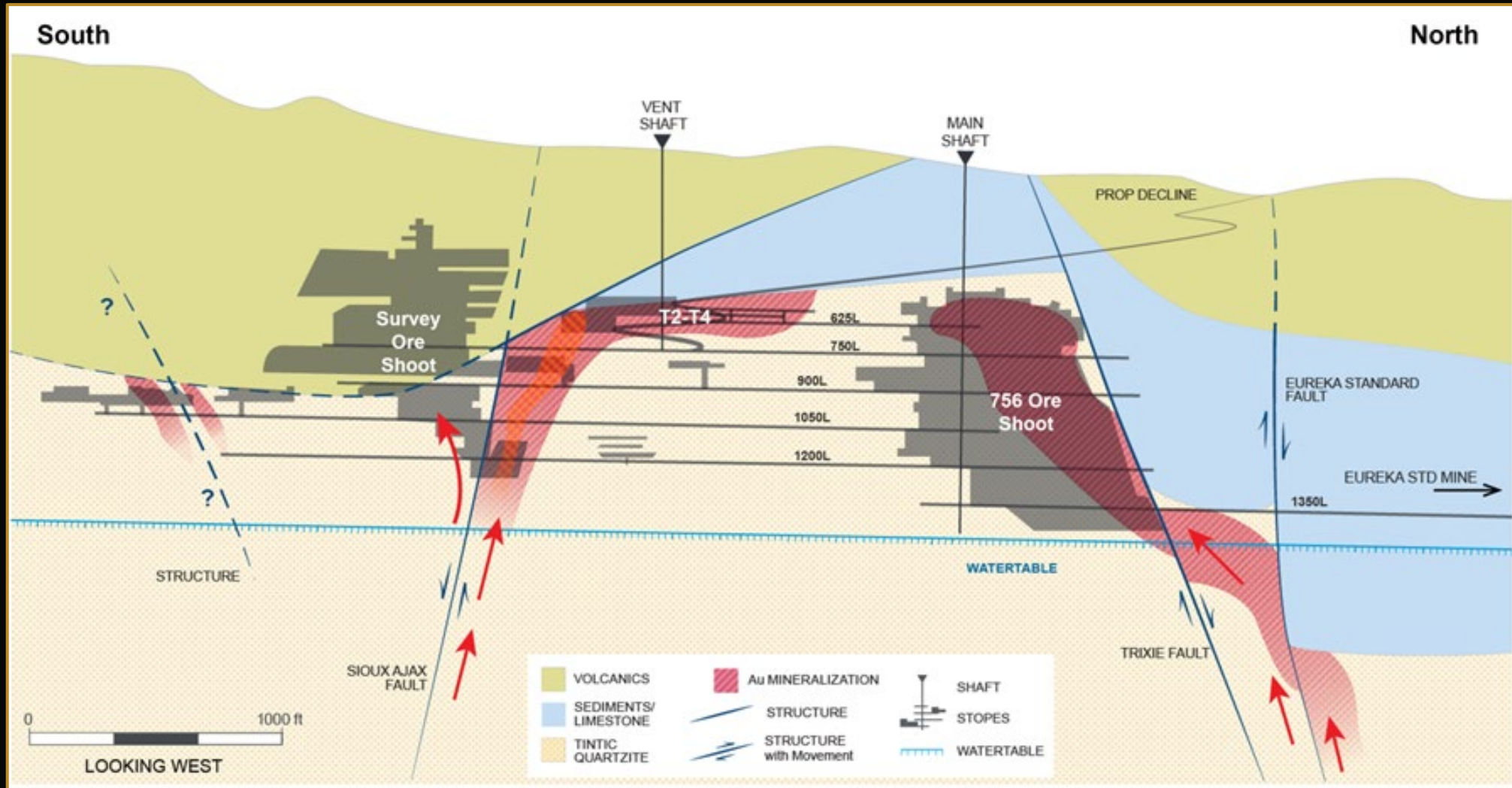

Trixie Mine Mineralization



T2 Discrete Breccia Zone



- 1-2 ft (0.2-0.8m)-wide zone of high-grade Au
- Native Au and rare Au-Ag-rich +/- Cu- telluride minerals with quartz.
 - E.g., Xocomecalite, hessite, goldfieldite, bezmertnovite, petzite, rickardite
- Highest assayed to date 467 oz/t Au (16,381 g/t Au over 0.43 meters in a chip sample)

T4 Stockwork Zone



- 10-80 ft. (3 to 25 m)-wide
- Typical grade of 0.3 to 1.0 oz/t (10 to 34 g/t) in T2 hanging-wall
- Au - Ag-rich mineralization in host rock quartzite with quartz-barite-sulfosalt stockwork veining



Underground Sampling and Mapping

Trixie Mine: T2 Face Sampling



T2: High Sulphidation Ledge Structure

- A total of 1,150 face samples collected in 2021
- Average uncut, unweighted grade: **5.49 oz/t Au (188.23 g/t Au) , 6.64 oz/t Ag (227.66 g/t Ag)**
- Three exploration cross cuts were developed east from the first sill cut on the T2 structure, intersecting significant Au mineralization also observed in “up” drillhole, relating to the T4 mineralization.
- T2 Sill 1 mining cut:
 - **224 ft. strike: average 4.45 ft. @ 9.27 oz/t Au (68.3 m strike: average 1.36m @ 354.9 g/t Au)**
- T2 Sill 2 mining cut:
 - **455 ft strike: average 5.10 ft. @ 12.64 oz/t Au (138.7m strike: average 1.55 m at 433.37 g/t Au)**

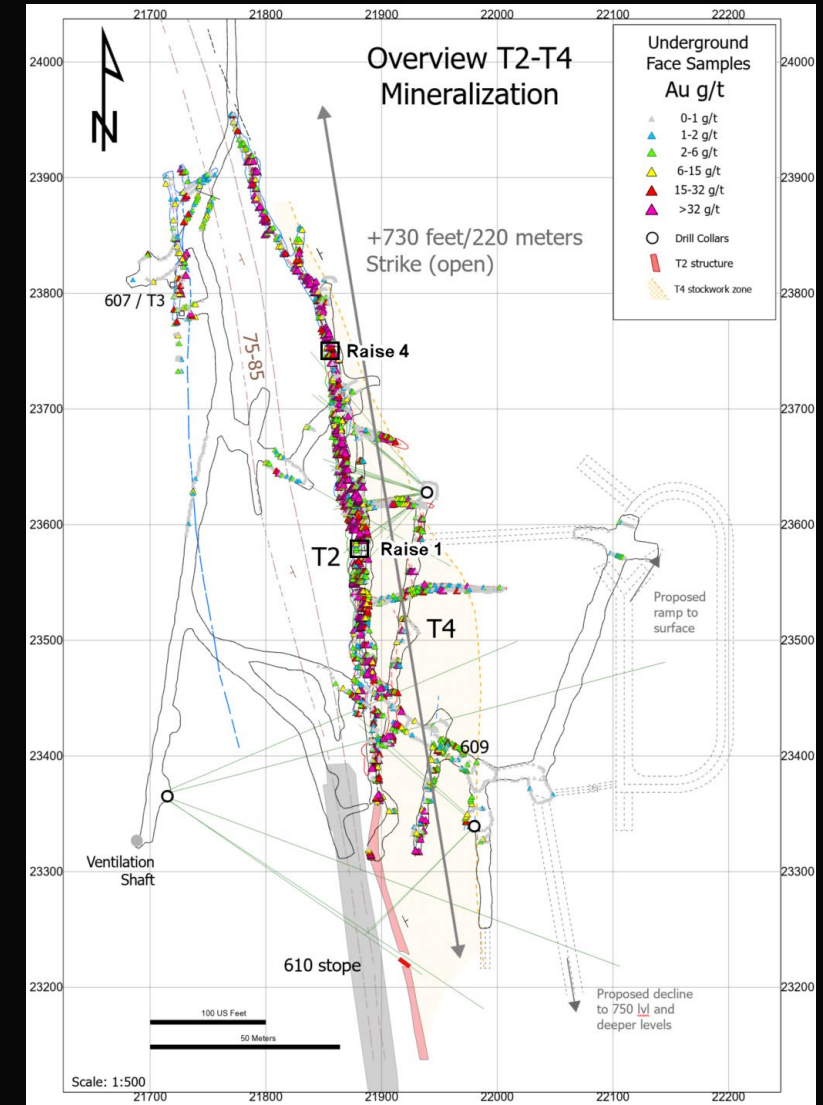

Trixie Mine: T4 Face Sampling



T4: Stockwork Mineralization

- A total of 946 face samples collected in 2021
- Average uncut grade: **0.27 oz/t Au, and 1.59 oz/t Ag**
- Xcut 1:
 - 15 ft. @ 2.03 oz/t Au (back) 4.57 m @ 69.6 g/t Au**
- Xcut 2:
 - 16 ft. @ 0.76 oz/t Au (north rib) 4.88 m @ 26.06 g/t Au**
 - 12 ft. @ 0.51 oz/t Au (south rib) 3.66 m @ 17.49 g/t Au**
- Xcut 3:
 - 14 ft. @ 0.69 oz/t Au (back) 4.27 m @ 23.66 g/t Au**
 - 14 ft. @ 0.44 oz/t Au (south rib) 4.27 m @ 15.09 g/t Au**
- Wildcat Drift:
 - 149 ft. strike: average 6.9 ft. @ 0.69 oz/t Au (45.4 m strike: average 2.1m @ 26.66 g/t Au)**

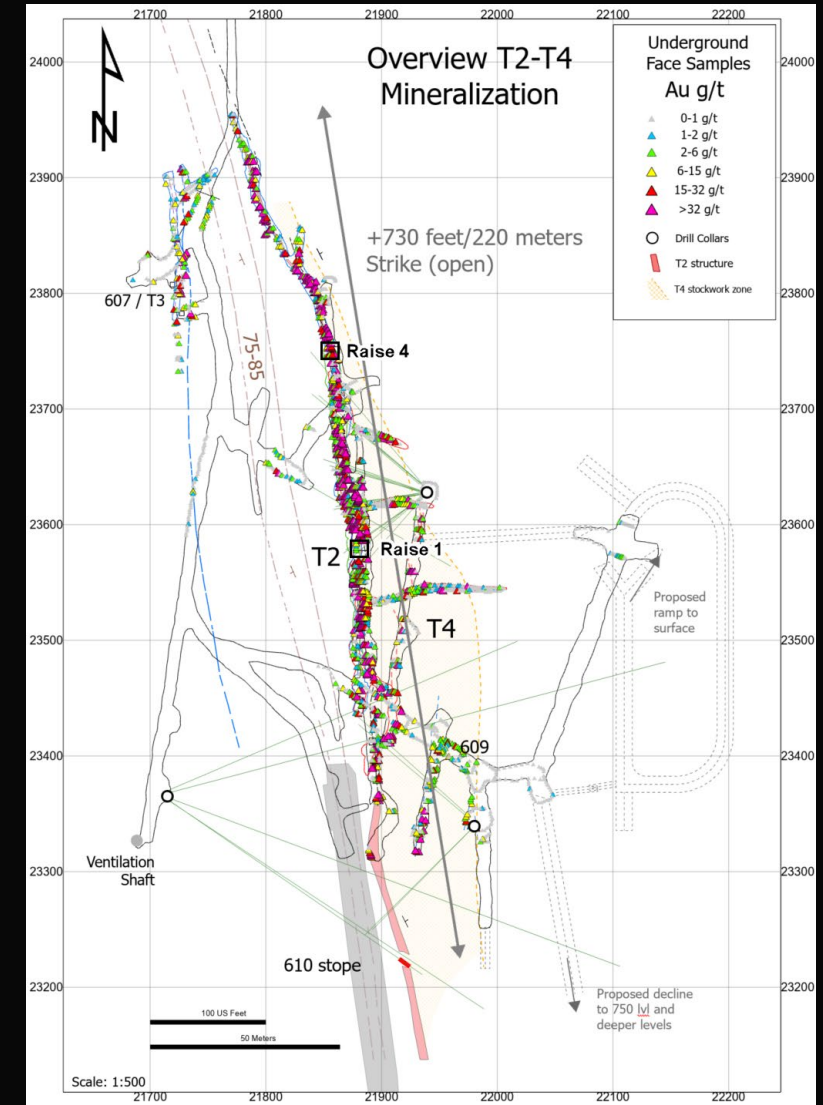

T2 Structure – Mining Cuts – Sill 1					
Mining North of Raise 1					
Distance of Mining Face North of Raise 1	Composited Sample Width		Face Grade Uncut Au		
	(ft)	(ft)	(m)	(oz/t)	(g/t)
10	6.0	1.8	11.96	410.06	
14	4.0	1.2	18.42	631.54	
18	4.0	1.2	5.93	203.31	
22	5.0	1.5	16.19	555.09	
37	4.0	1.2	0.65	22.29	
40	4.1	1.2	1.02	34.97	
44	3.0	0.9	4.93	169.03	
48	5.7	1.7	1.59	54.51	
56	3.0	0.9	10.95	375.43	
59	4.3	1.3	0.66	22.63	
61	4.2	1.3	3.79	129.94	
66	3.2	1.0	4.74	162.51	
67	6.0	1.8	3.92	134.40	
71	4.5	1.4	0.24	8.23	
81	4.8	1.5	6.8	233.14	
86	4.0	1.2	2.98	102.17	
89	4.6	1.4	10.48	359.31	
91	5.0	1.5	8.88	304.46	
100	5.0	1.5	79.91	2739.77	
102	5.2	1.6	40.35	1383.43	
104	4.5	1.4	8.81	302.06	
119	4.6	1.4	5.39	184.80	
131	5.0	1.5	1.53	52.46	
141	4.0	1.2	1.39	47.66	
Total Length of Sill (ft)	Average Width of Mineralization Along Sill Cut		Average Grade Au		
149	4.49	1.37	11.11	380.91	

T2 Structure – Mining Cuts – Sill 1					
Mining South of Raise 1					
Distance of Mining Face North of Raise 4	Composited Sample Width		Face Grade Uncut Au		
	(ft)	(ft)	(m)	(oz/t)	(g/t)
13	2.00	0.61	4.11	1.25	
17	5.00	1.52	0.94	0.29	
29	4.00	1.22	1.14	0.35	
32	4.00	1.22	61.72	18.81	
34	4.00	1.22	1.55	0.47	
40	3.50	1.07	4.21	1.28	
41	4.60	1.40	4.32	1.32	
46	5.40	1.65	0.38	0.12	
53	6.00	1.83	0.04	0.01	
64	5.00	1.52	0.05	0.02	
74	3.00	0.91	0.83	0.25	
75	6.00	1.83	3.00	0.91	
87	5.00	1.52	0.04	0.01	
93	7.40	2.26	0.02	0.01	
96	3.00	0.91	0.06	0.02	
104	5.00	1.52	0.12	0.04	
109	6.00	1.83	0.06	0.02	
124	5.50	1.68	1.29	0.39	
133	5.30	1.62	0.26	0.08	
136	4.40	1.34	0.56	0.17	
138	5.20	1.58	0.36	0.11	
Total Length of Sill (ft)	Average Width of Mineralization Along Sill Cut (ft)		Average Grade Au		
138	4.73	1.44	3.45	118.29	



T2 Structure – Mining Cuts – Sill 2					
Mining North of Raise 1					
Distance of Mining Face North of Raise 1 (ft)	Composited Sample Width		Face Grade Uncut Au		
	(ft)	(m)	(oz/t)	(g/t)	
14.1		3.40	1.04	0.06	2.06
23		4.00	1.22	0.21	7.20
37		6.00	1.83	2.09	71.66
54		3.60	1.10	8.38	287.31
70		3.00	0.91	0.01	0.34
78		3.60	1.10	24.89	853.37
81		4.30	1.31	3.18	109.03
85		4.00	1.22	5.20	178.29
95		3.50	1.07	0.23	7.89
110		10.00	3.05	1.08	37.03
118		9.00	2.74	0.21	7.20
126		8.00	2.44	0.03	1.03
140		4.50	1.37	75.24	2579.66
148		3.30	1.01	0.92	31.54
151.5		7.30	2.23	1.27	43.54
158		4.40	1.34	0.51	17.49
165		3.70	1.13	0.27	9.26
173		4.50	1.37	78.99	2708.23
182		5.60	1.71	21.66	742.63
185		4.40	1.34	21.70	744.00
188		4.00	1.22	4.60	157.71
196		5.40	1.65	0.10	3.43
200		6.80	2.07	0.46	15.77
203		6.50	1.98	3.89	133.37
206		7.30	2.23	6.81	233.49
210		4.50	1.37	7.50	257.14
212		4.60	1.40	8.64	296.23
216		5.50	1.68	6.60	226.29
217		4.80	1.46	1.18	40.46
220		4.20	1.28	9.55	327.43
227		6.50	1.98	16.53	566.74
231		6.70	2.04	101.24	3471.08
232		6.50	1.98	12.34	423.09
Total Length of Sill (ft)	Average Width of Mineralization Along Sill Cut (ft)		Average Grade Au (oz/t)		
232		5.25	1.60	12.90	442.29

T2 Structure – Mining Cuts – Sill 2					
Mining North of Raise 4					
Distance of Mining Face North of Raise 4 (ft)	Composited Sample Width		Face Grade Uncut Au		
	(ft)	(m)	(oz/t)	(g/t)	
3		4.4	1.3	0.5	17.49
10		3.7	1.1	0.3	9.26
32		4.5	1.4	79.0	2,708.23
27		5.6	1.7	21.7	742.63
30		4.4	1.3	21.7	744.00
33		4.0	1.2	4.6	157.71
41		5.4	1.6	0.1	3.43
45		6.8	2.1	0.5	15.77
48		6.5	2.0	3.9	133.37
51		5.3	1.6	6.8	233.49
55		4.5	1.4	7.5	257.14
57		4.6	1.4	8.6	296.23
61		5.5	1.7	6.6	226.29
62		4.8	1.5	1.2	40.46
65		4.2	1.3	9.6	327.43
72		6.5	2.0	16.5	566.74
76		6.7	2.0	101.2	3,471.08
77		6.5	2.0	12.3	423.09
84		6.8	2.1	2.7	93.60
90		4.5	1.4	67.7	2,321.83
92		4.0	1.2	0.5	16.46
94		4.6	1.4	1.0	35.31
101		3.5	1.1	0.2	6.17
107		5.0	1.5	0.1	1.71
109		5.5	1.7	0.1	4.80
117		5.4	1.6	0.6	19.20
124		4.0	1.2	2.1	72.34
127		5.3	1.6	3.8	129.94
132		5.9	1.8	2.0	67.89
138		4.3	1.3	11.7	399.43
145		4.8	1.5	29.0	992.57
148		4.0	1.2	4.7	162.17
155		2.7	0.8	0.4	14.74
Total Length of Sill (ft)	Average Width of Mineralization Along Sill Cut		Average Grade Au		
165		5.03	1.53	13.00	445.71



Trixie Mine: T2 Grade Continuity



The main T2 structure shows excellent continuity of grades

In-Situ T2 Mineralization



Composite Face Sampling Grade Continuity by Tintic from Underground 625 Level (not including splays and crosscuts) – October 2021

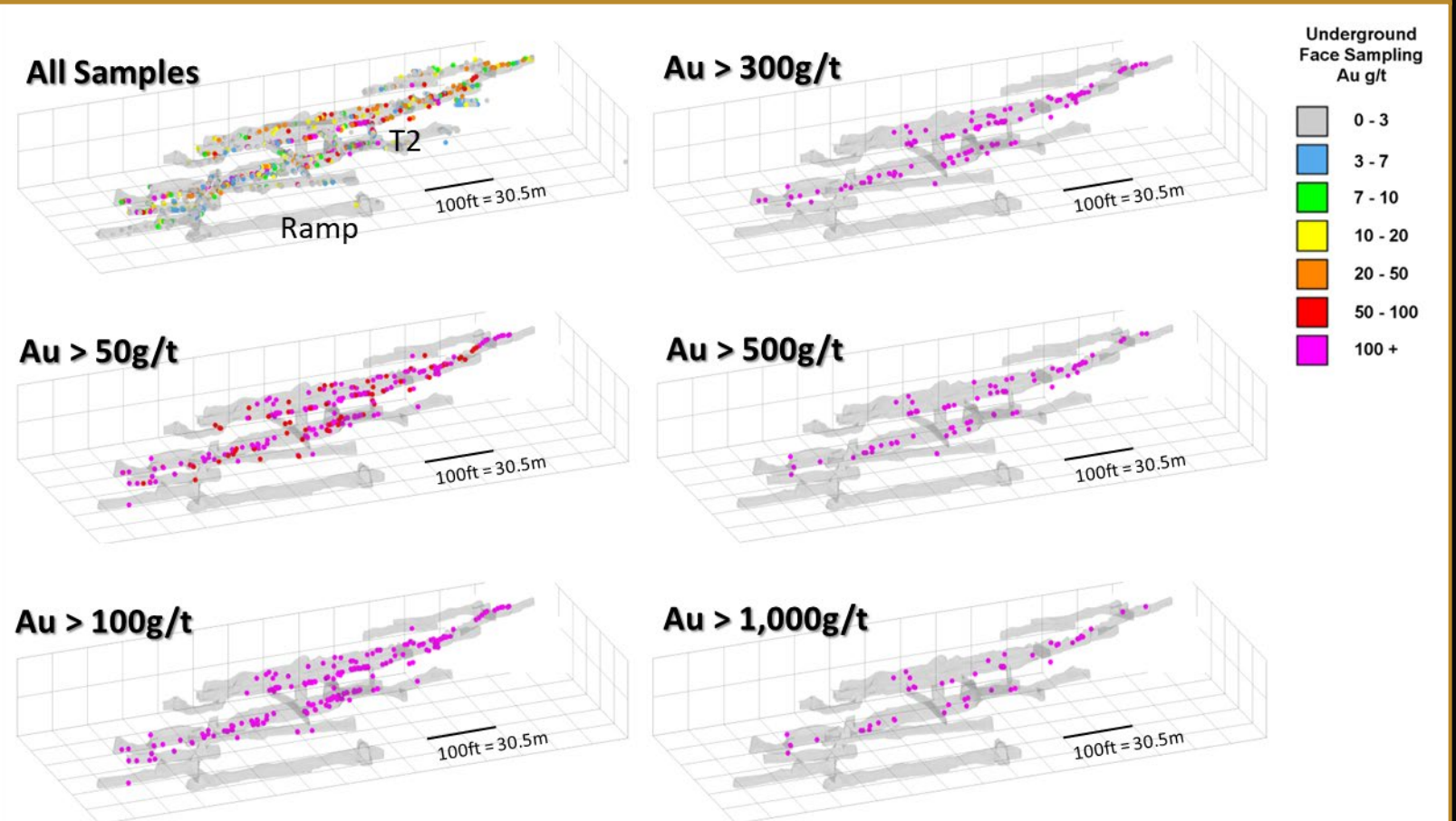



Underground Drilling

Underground Drilling Methodology



- Currently two drill rigs in operation
- HQ diamond drill (UG) and surface RC drill
- Sampling completed onsite using ½ cut drill core
- Samples processed by ALS Laboratory in Reno, NV
 - Gold Fire Assay and Multi-Element Four-Acid Digest
- All assay batches include full QA-QC standard and blank inserts

2021 Underground Drilling Highlights

- Drilling assays generally report lower grades than face sampling assays due to the nuggety nature of the gold system
- Wider-bore HQ drill samples have shown more success in providing realistic assay results
- Drill assays underscore the importance of “drilling for structure, drifting for grade”
- Existing underground development at Trixie allows fast-tracking of drilling and exploration cross-cuts
- Underground drill stations can be placed near the target zones with minimal additional mine development

Hole ID	Structure	From (ft)	To (ft)	Interval (ft)	Interval (m)	Au (oz/t)	Au (g/t)	Ag (oz/t)	Ag (g/t)
TUG-625-013	T2-T4	63.2	123.0	48.0	14.6	1.4	49.0	2.7	91.9
TUG-625-002	T2	238.0	266.5	28.5	8.7	0.6	21.9	2.6	90.2
TUG-625-001	T2	318.5	332.0	13.5	4.1	0.2	7.9	0.5	15.8
TUG-625-005	T2	167.5	187.5	13.4	4.1	0.1	3.8	4.8	162.9
TUG-625-023	T2	125.0	126.0	1.0	0.3	0.2	5.5	2.9	97.7
TUG-625-018	T2	107.5	118.5	11.0	3.4	0.1	2.4	3.6	121.7
TUG-625-011	T4 Stockwork	71.0	89.2	18.2	5.5	0.3	11.7	1.7	57.9
TUG-625-023	T4 Stockwork	33.0	49.0	16.0	4.9	0.4	12.0	1.3	42.9
TUG-625-017	T4 Stockwork	63.5	133.2	69.7	21.2	0.2	7.5	2.3	77.5
TUG-625-010	T4 Stockwork	59.0	115.5	56.5	17.2	0.1	4.1	3.6	122.1
TUG-625-012	T4 Stockwork	59.0	99.0	40.0	12.2	0.1	3.1	1.0	33.3
TUG-625-006	T2	44.0	49.5	5.5	1.7	0.6	20.2	1.1	39.1
TUG-625-014	T2	84.0	88.0	4.0	1.2	0.4	14.1	0.6	20.6
TUG-625-008	T2	60.0	67.0	7.0	2.1	0.3	11.7	0.4	15.1
TUG-625-007	T2	79.0	81.0	2.0	0.6	0.1	4.5	0.3	11.0
TUG-625-015	T2	93.0	97.0	4.0	1.2	0.1	3.1	0.2	6.2
TUG-625-009	T2	100.6	102.0	1.4	0.4	0.1	2.7	1.5	49.7
TUG-625-016	T2	107.2	128.0	20.8	6.3	0.0	0.3	0.0	0.3
TUG-625-004A	75-85	162.0	166.0	4.0	1.2	0.6	19.2	0.6	21.9
TUG-625-005	75-85 / T2	169.5	183.6	14.1	4.3	0.5	18.2	5.3	181.0

2022 Objectives



- Complete an initial NI 43-101 compliant mineral resource estimate and operational report at Trixie as a foundation for a future PEA
- Initiate advanced independent metallurgical and geotechnical studies to support a future PEA
- Continue target generative work within and surrounding the Trixie mine and commence surface drilling of targets for ongoing resource development

2022 Objectives and Budget



Work Program	Cost (USD)
Underground exploration drilling	\$ 9,000,000
Complete Initial 43-101 Mineral Resource Estimate	\$ 500,000
Metallurgical Testing and Geotechnical Studies	\$ 250,000
Database compilation, target generation and exploration permitting	\$ 750,000
Operational permits for ramp, processing and tailings	\$ 1,000,000
Portal Ramp development to 625 Level	\$ 10,500,000
Equipment and capital items	\$ 1,500,000
Environmental Studies	\$ 1,000,000
Contingency (15%)	\$ 2,940,000
Total	\$ 27,440,000

Trixie Mine Plan and Schedule



- Currently UG access is by shaft only to the 625L and 750L
- Production averaging 35 tpd. Tonnage limited by shaft logistics
- Targeting initial resource by end of 2022
- Current estimated tonnage in T2 area currently allows for 14 months of narrow vein mining
- Estimate to complete surface decline is Q2 2023. All permitting is in place and surface access roads and portal face excavation has been completed
- The decline will allow mining of T4 material at much higher tonnages and continued development of the lower levels of the Trixie



Trixie Decline Development



- 4,550 ft. (1390 m) of decline development from surface to connect to the 625 level
- Approx. 4,300 ft. (1310 m) to be driven from surface, and 350 ft. (106 m) to be driven from underground
- Decline cross-section size is 16 x 16 ft. (5 x 5 m)
- Muckbays excavated every 300 ft. (100 m) that can be later used for underground exploration platforms
- Planned to continue decline to the 750 Level once breakthrough is achieved at the 625 Level
- The decline is designed to intercept major known structures in the area at 90 deg. to minimize driving distance within the structure from 625L to surface

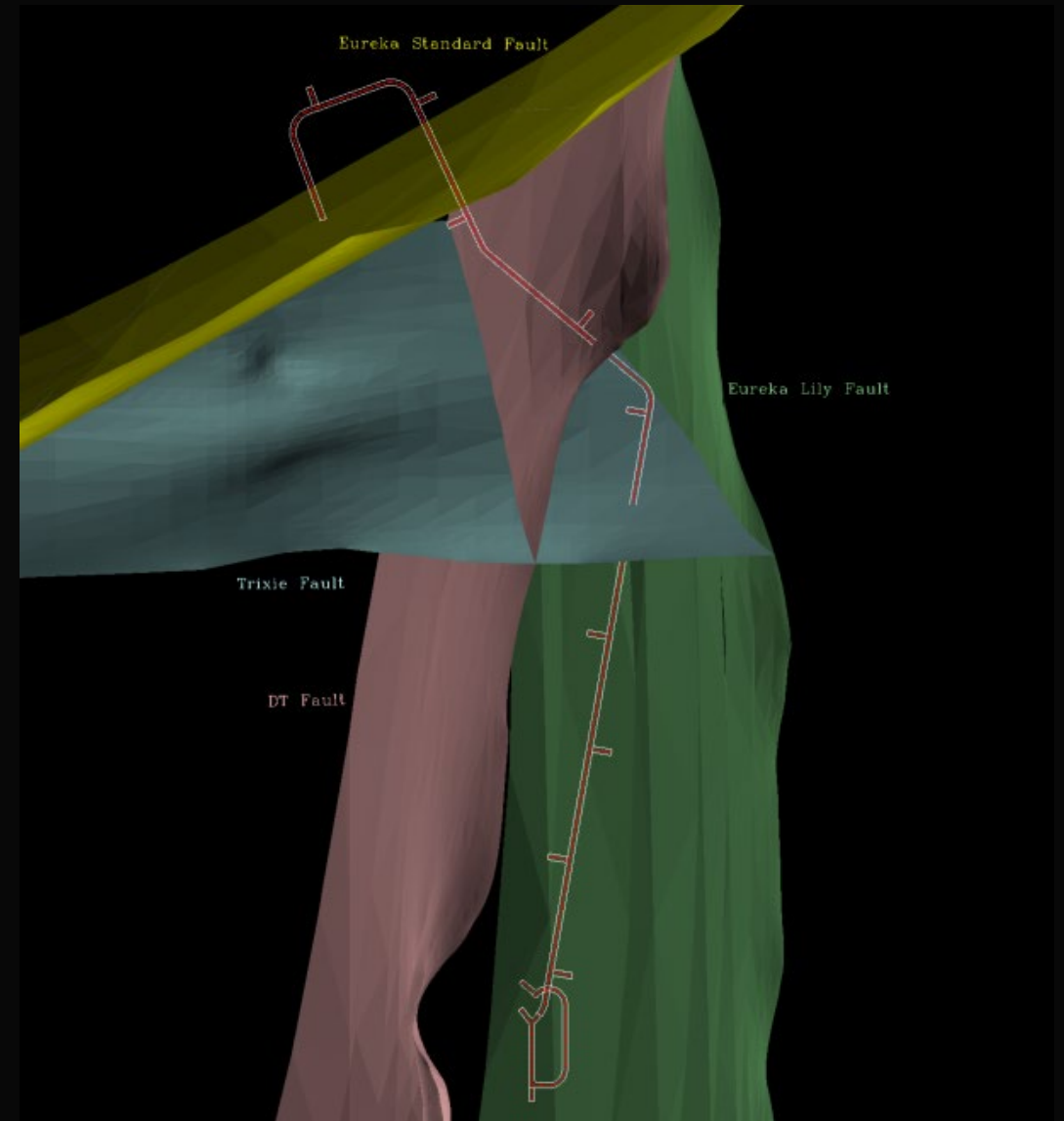

Trixie Decline Development



- 820 ft. (250 m) of new surface road constructed, and 700 ft. (215 m) of existing road has been improved between the Trixie and the decline portal entrance
- Drainage in the portal area has been established and a 30-inch corrugated metal culvert installed
- Portal face has been excavated in preparation to receive a core drill to carry out geotechnical drilling





Exploration Potential

Tintic District Exploration Model



Fast track to New Discoveries:

- Well established extant underground infrastructure
- Extensive library of legacy datasets covering the entire property

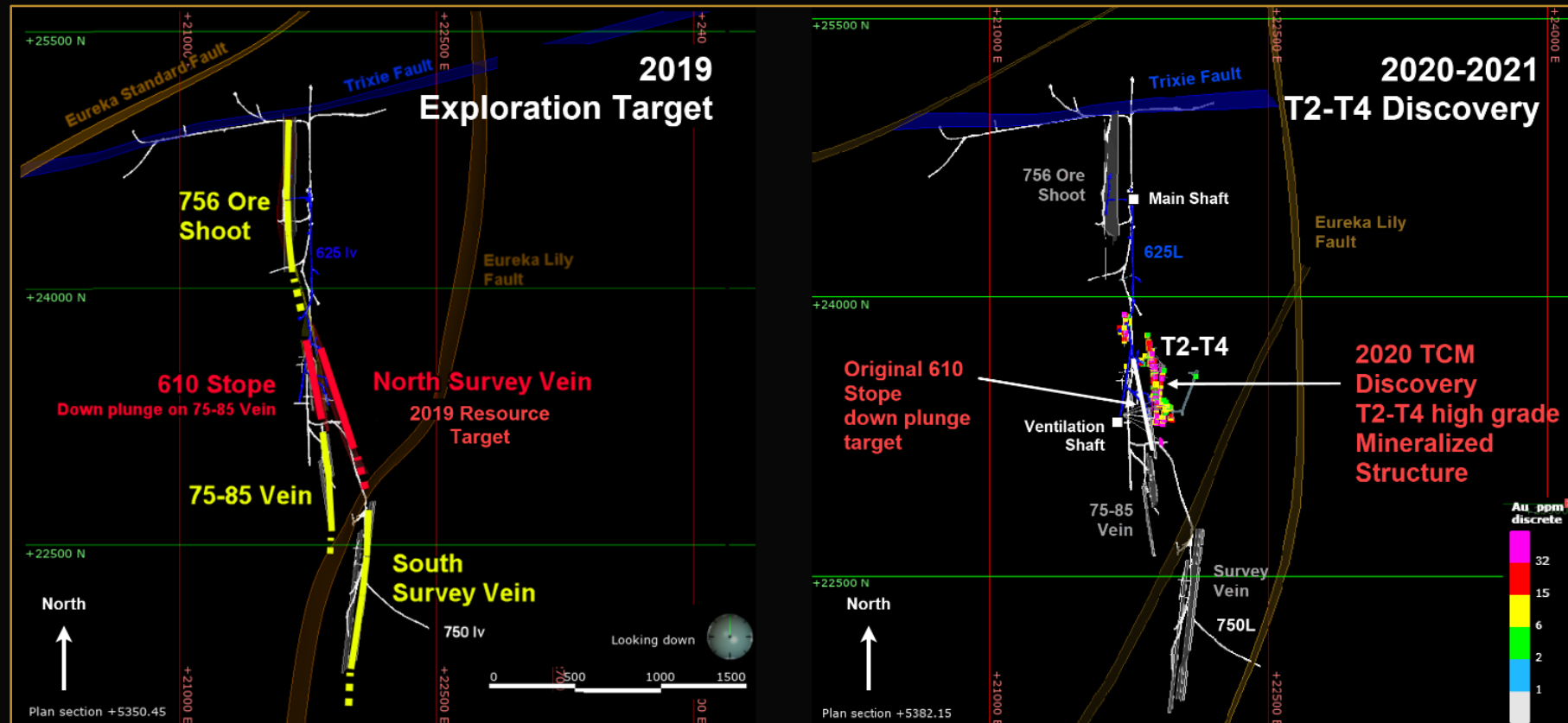

Trixie Mine: Exploration Potential



- Six levels of historical development accessed by a shaft to a depth of 412m (1,350 ft.)
- Mineralization open at depth
- Discovery of the T2 structure supports the untapped potential of the area
- Exploration in 2022 will target potential on T2, T4 structures and stockwork zones
- Phase 2 exploration will continue drilling and drifting east of the Trixie mine along T2 structure over a 1 km strike length and extending down to 300 m of depth

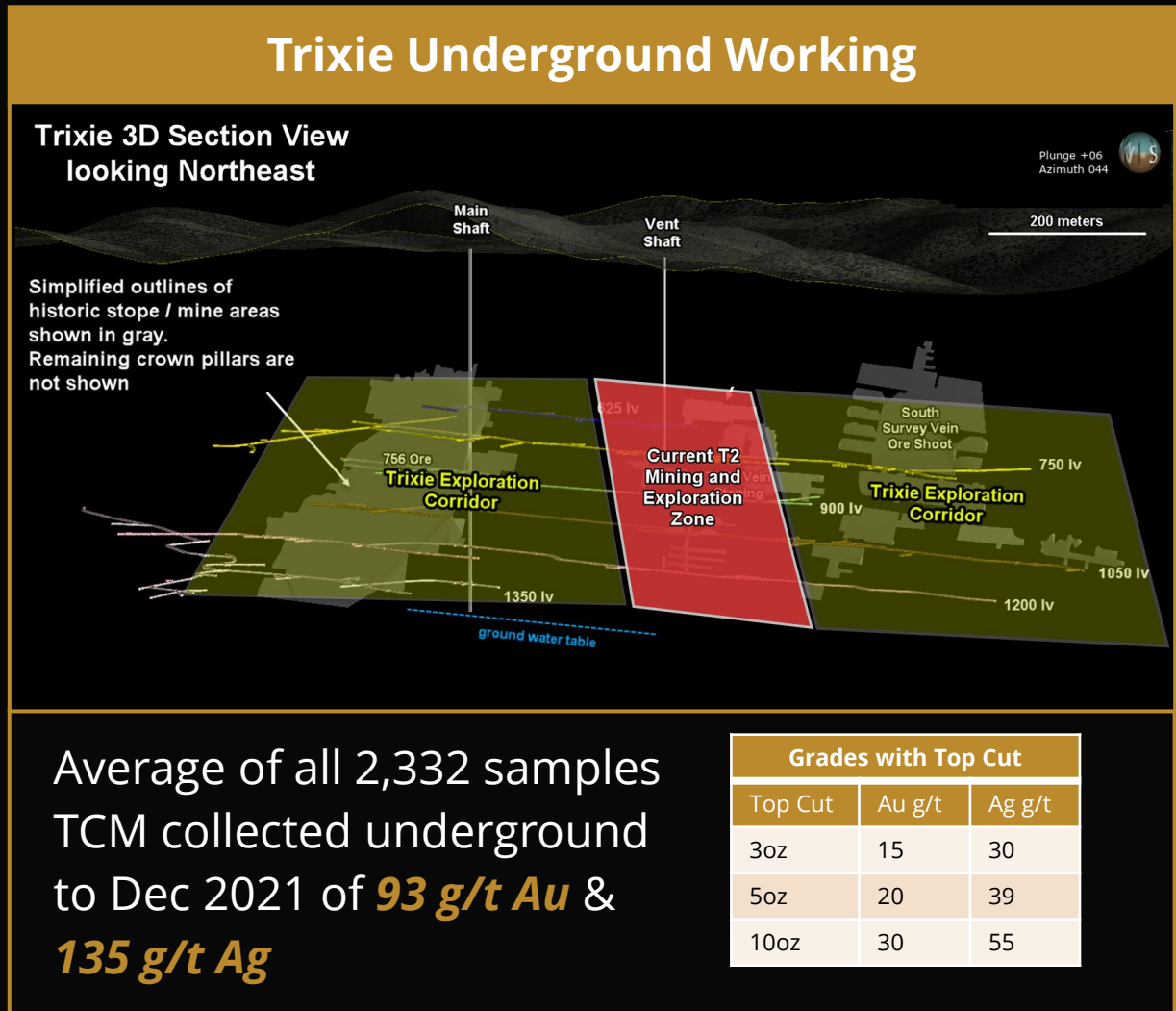

Trixie Mine: Trixie West Target



Trixie West Exploration Target

- Significant exploration target
- Located 2,000 ft (610 m) west of the Trixie Deposit
- Structurally analogous to Trixie Deposit
- Narrow veins hosted within volcanics
- Initial assays @ 0.54 oz/t over 5 ft (18.5 g/t Au over 1.5 m)

Location of Trixie West Target Relative to Trixie Deposit

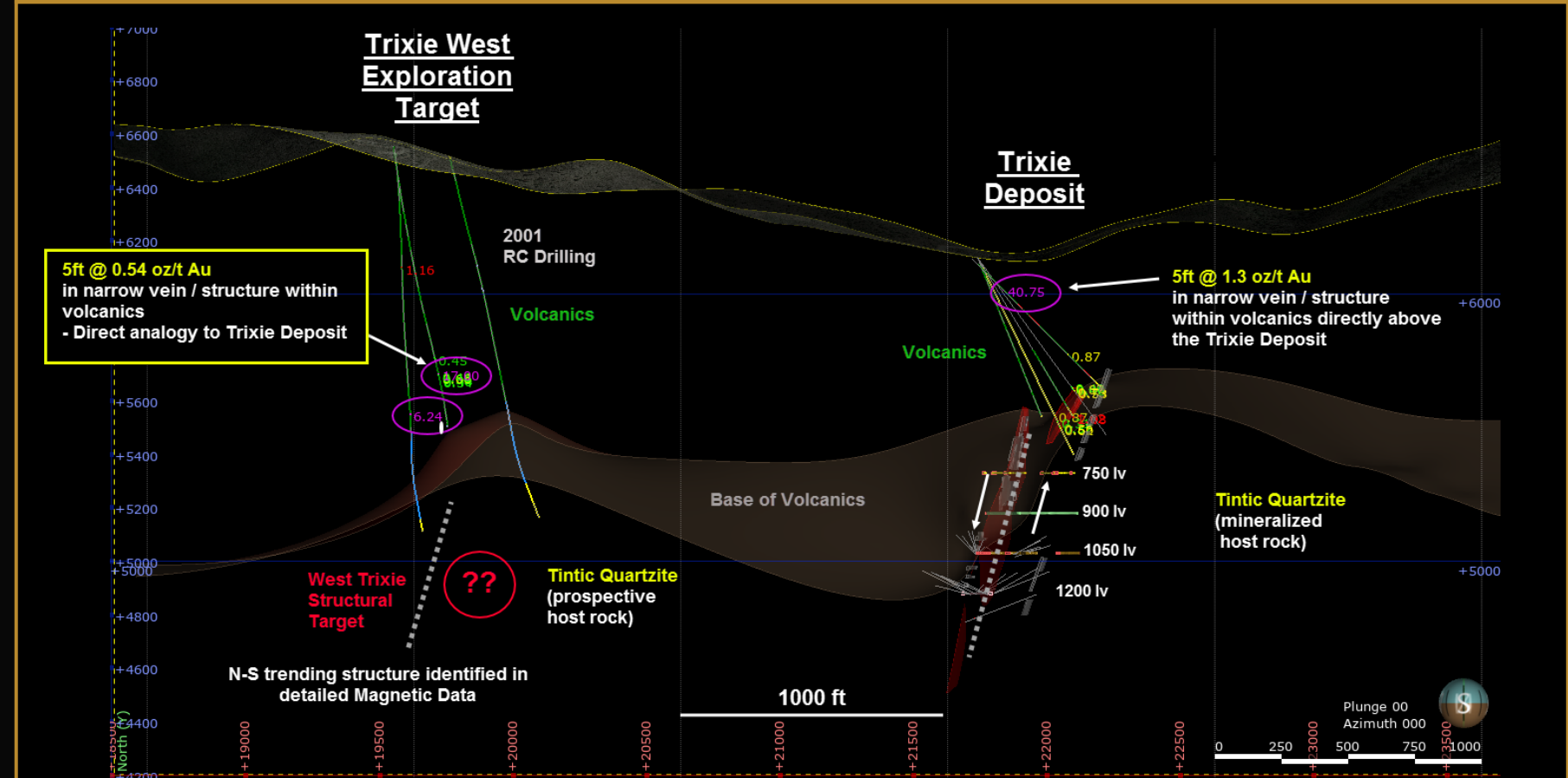

Trixie Area Surface Drill Proposal



- Second phase of exploration is continued drilling East of the Trixie mine along T2 structure over a 3000 ft. (1 km) strike length and 1000 ft. (300 m) of depth
- Defining along strike potential of T2 structure
- Identify additional targets within Trixie
- Proposed Surface RC Drilling
 - 50,000 ft. (15,000 m) of proposed drilling with 2 rigs
 - Extended archaeological survey / approvals southwards, to facilitate expansion of drilling program

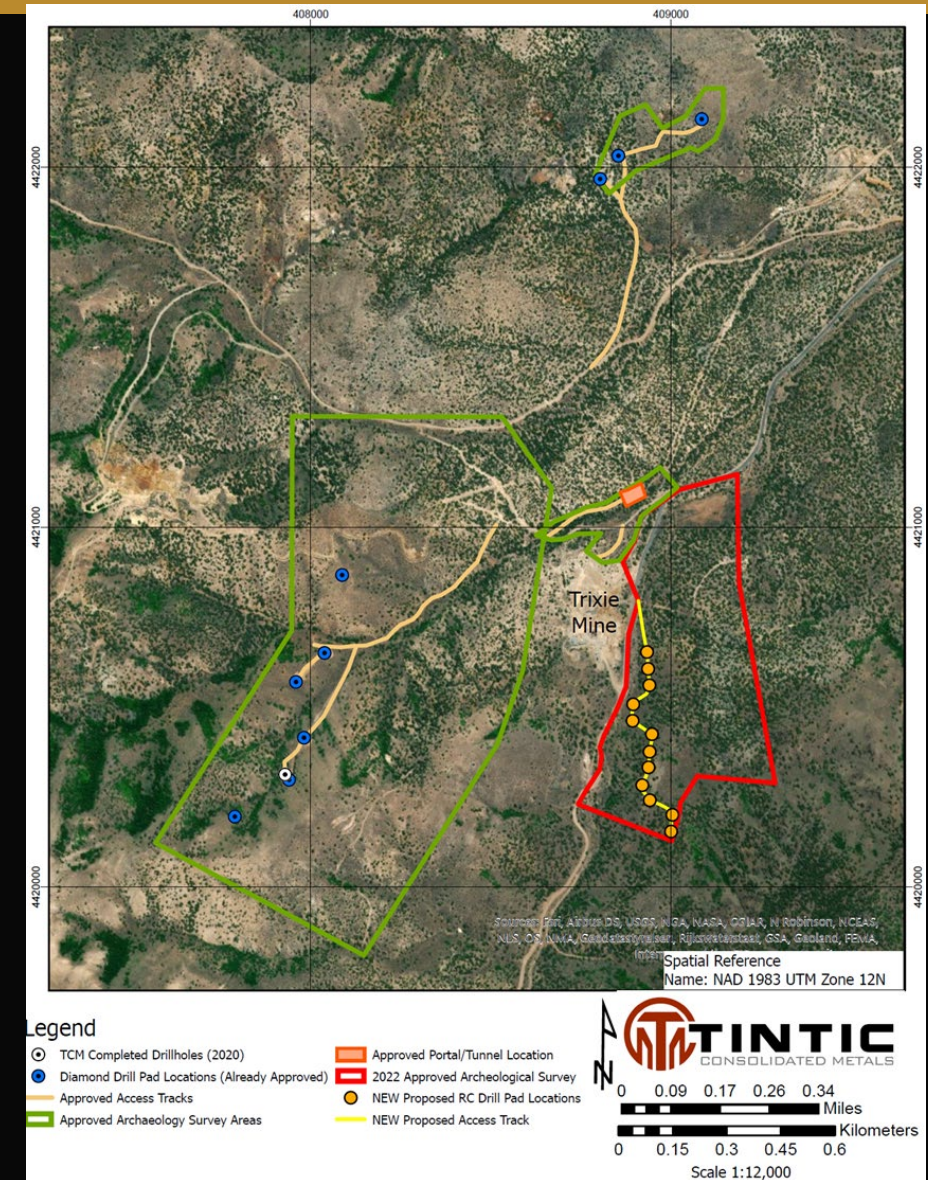

Regional Exploration Potential



- **East Trixie – South Apex Structural Corridor**
 - Structural setting to that at Trixie and Eureka Standard mines
 - Depth of top of Tintic Quartzite at 600 ft. (183 m)
 - No modern exploration
 - Targeted but never tested by Kennecott in the 1970's
 - Follow up mapping and soil sampling
 - Extensive surface Drilling program planned

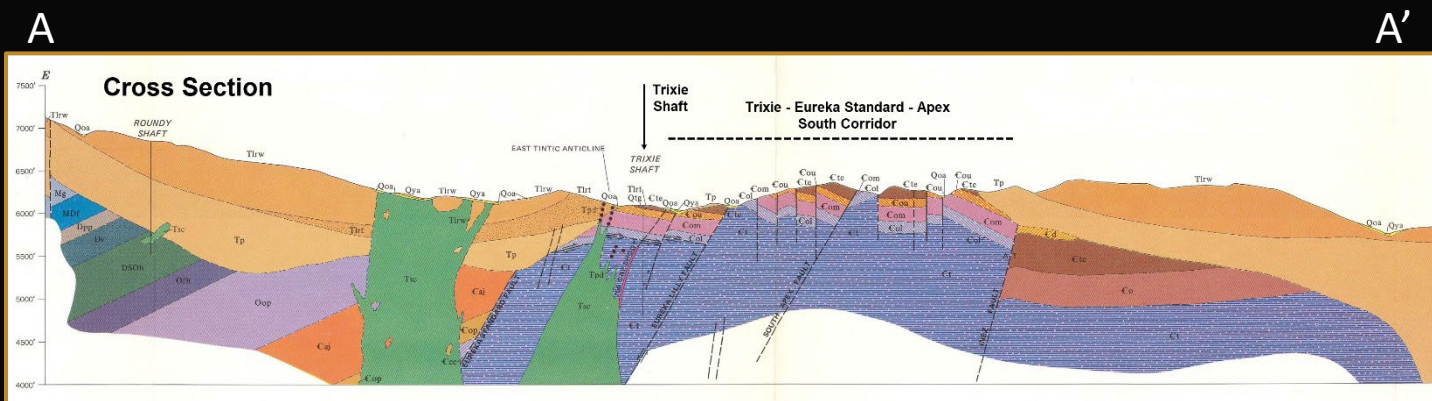

- **Trixie West Structural Corridor**
 - TCM drilled 2 holes in 2019, requires additional drilling that is fully permitted

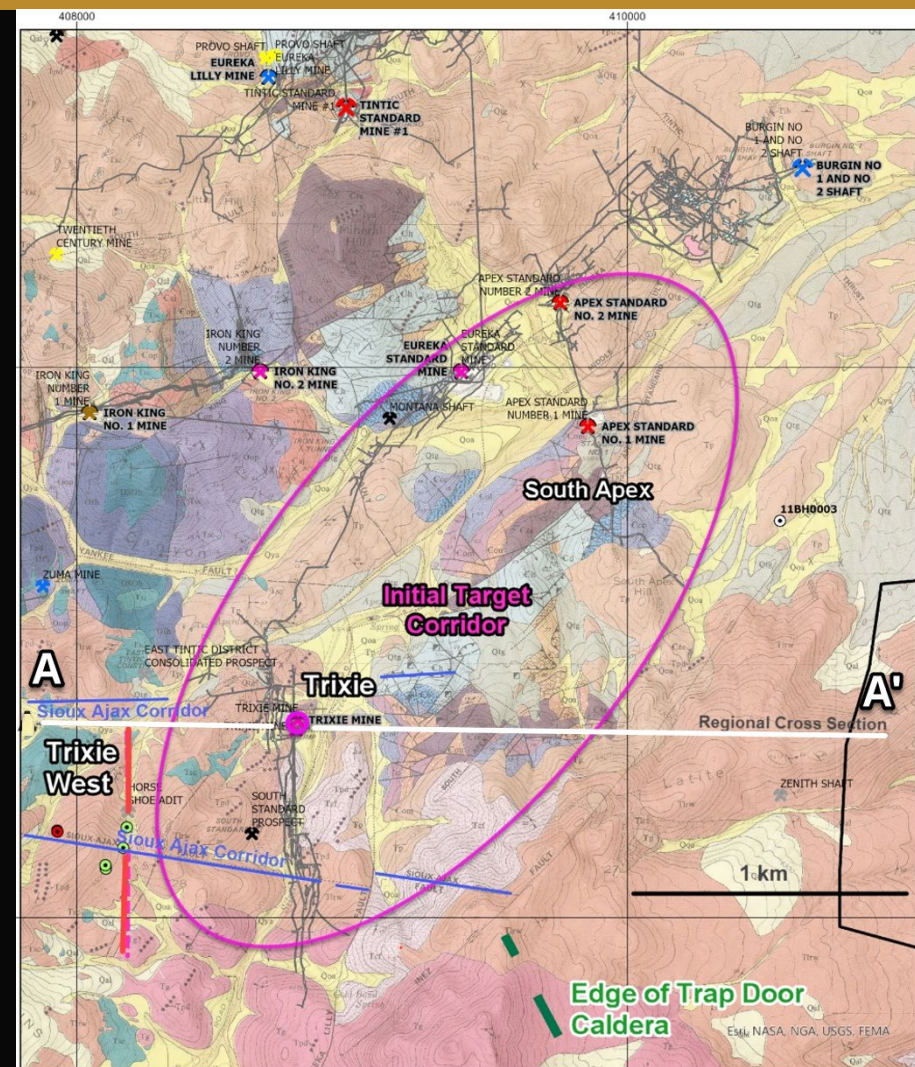

Legend

- Trap_Door_Caldera
- TCM Collars
- Tintic Utah TWRC
- Underground Mine Development
- TCM AOI

TINTIC CONSOLIDATED METALS LLC

Scale: 0 0.1 0.2 0.3 Kilometers

North Arrow

Source: Reference: Tintic, MO, 1911 (1914), Zone 12N, PGC, 1:50,000 (1914), Zone 12N, GCS: CGT, North American 1983, Datum: North American 1983

Regional Exploration Potential: Eureka Standard

- Epithermal Au-Ag along trend NNE of the Trixie mine
- Mineralization hosted in the brittle Tintic Quartzite with structural control along the East Tintic thrust fault.
- The main high-grade mineralized shoot plunges into the water table at 1,400 ft. (426m) and remains open at depth
- Gold grades averaged **>1.3 oz/t Au** into the water table

Select Historic Samples from the Eureka Standard Mine, ca. 1931

Location	Au (oz/t)	Ag (oz/t)	Number of Samples
1100 Level 7 th Floor (4772 ft)	1.070	20.0	40
1100 Level Sill Floor (4728 ft)	1.413	17.3	105
1300 Level 14 th Floor (4652 ft)	1.388	22.1	79
1200 Level Sill Floor (4612 ft)	1.305	12.0	31
1300 Level Sill Floor (4566 ft)	1.411	19.1	81
Winze Area	1.810	22.8	14
Weighted Average Grade	1.374	18.859	

Eureka Standard Ore Pile Hand Sample



Northeast Facing Geologic Cross Section Through the Eureka Standard Shaft
Paul Billingsley, 1931

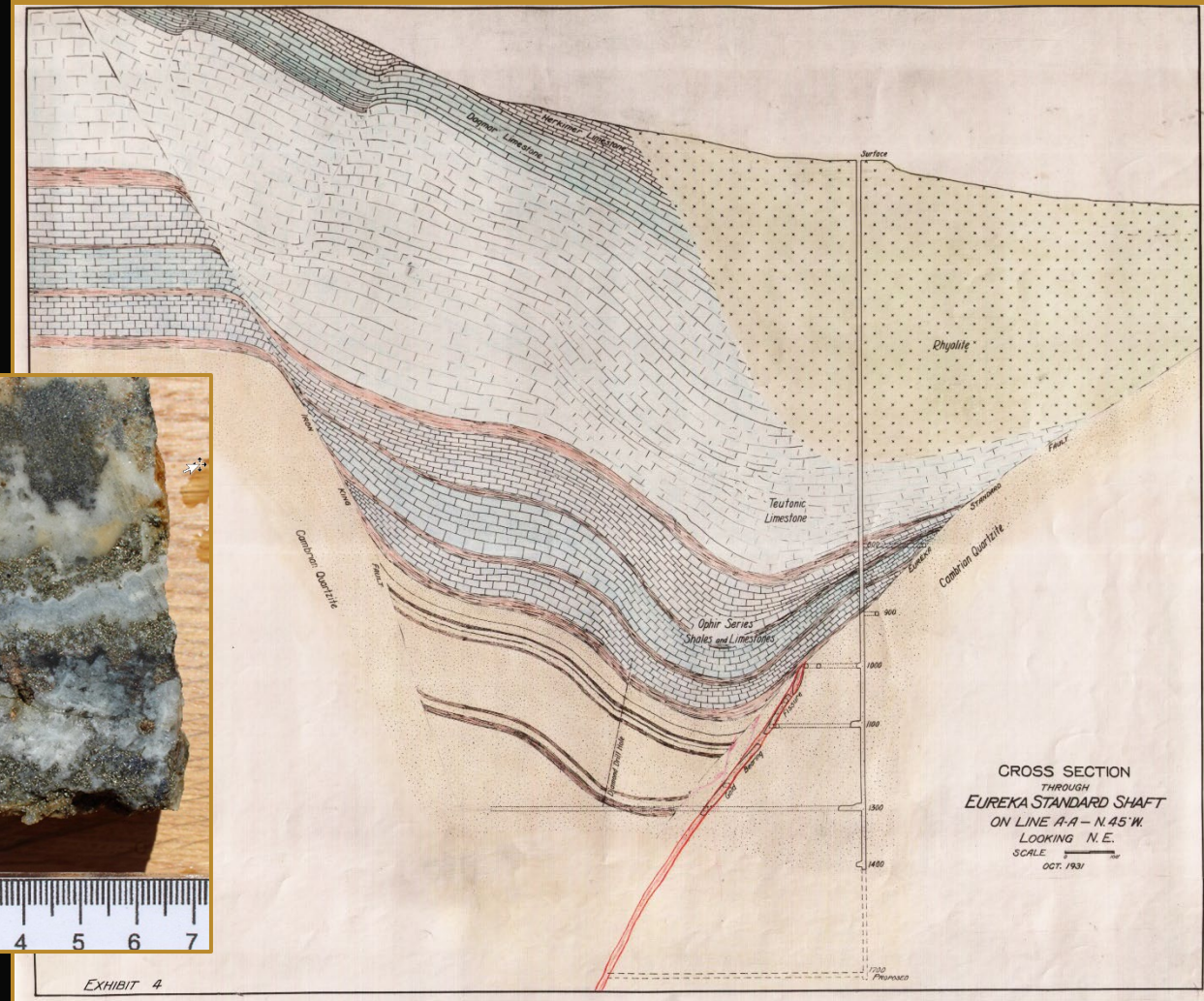

EXHIBIT 4

Regional Exploration Potential: North Lily



Trixie – North Lily

- Highly prospective 3 mi (5km) long Corridor
- Trixie – Eureka Standard – North Lily
- **Eureka Standard** operated until 1947, highest grade precious metal mine in district with av. Grade of **0.77 oz/t Au**
- **North Lily** operated until 1940s, Endline Dyke Fissure produced 151K oz gold at av. grade of **1.33 oz/t Au**

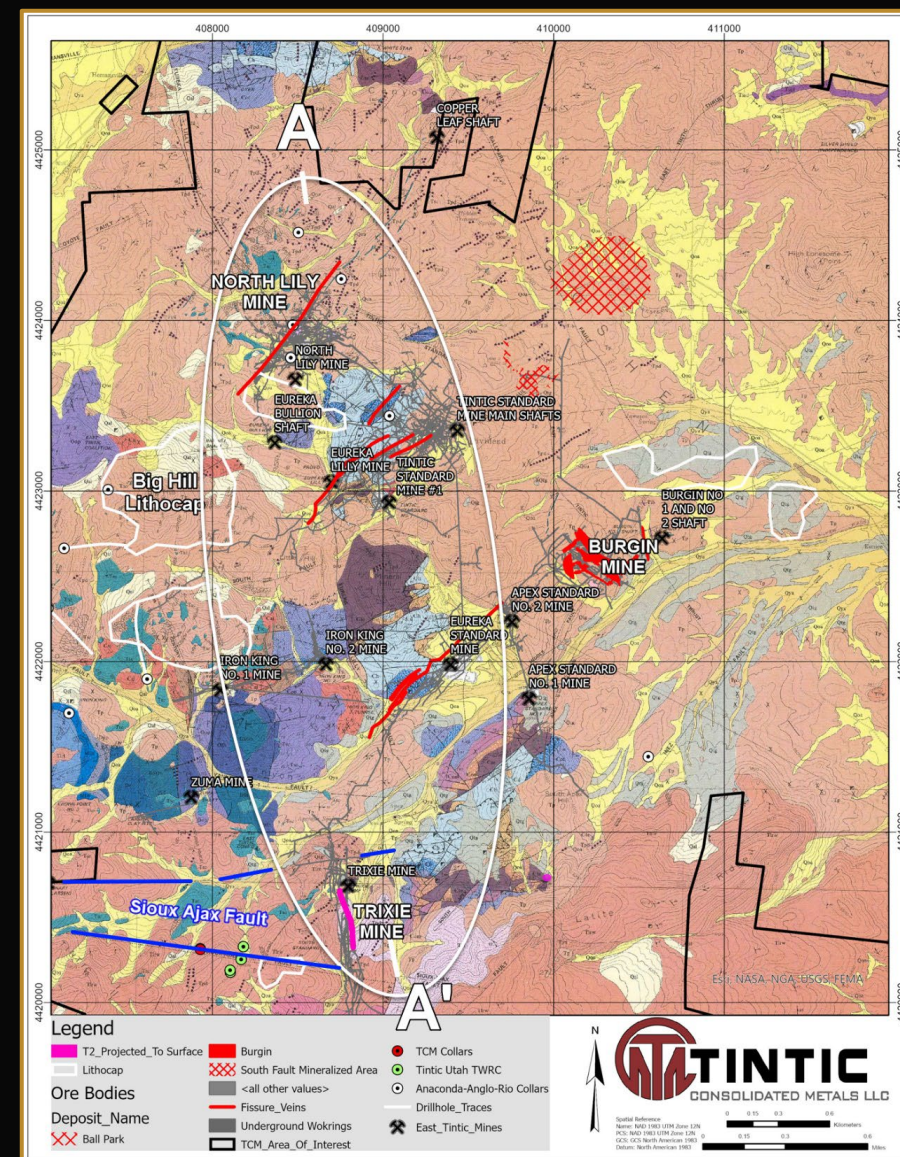
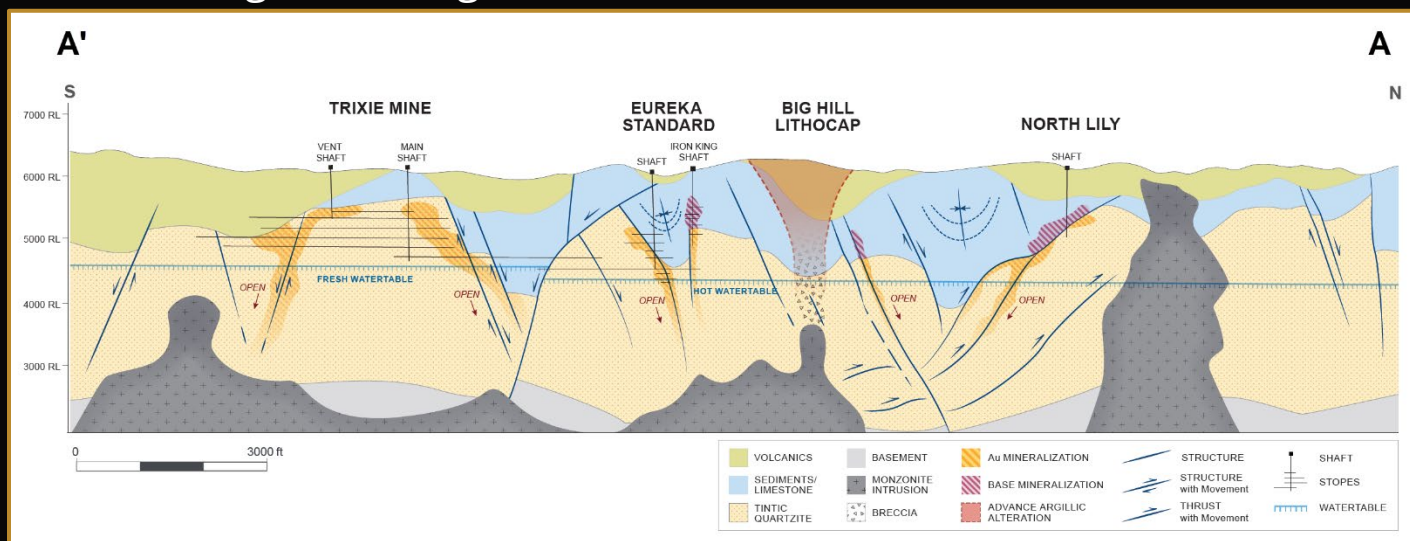

NORTH LILY HISTORIC OPERATION



- Historic data compilation to drive future targeting
- NE trending structures parallel to the Endline Dyke Fissure
- Down faulted southern end of Endline Dyke Fissure, downthrown by the Eureka Lily Fault
- Potential along strike towards the northeast
 - NE trending dyke swarm emanating from Big Hill lithocap / porphyry
 - Endline Dyke trend
 - 375,000 tons produced from 1927-1949 150K oz Au and 3.5M oz Ag

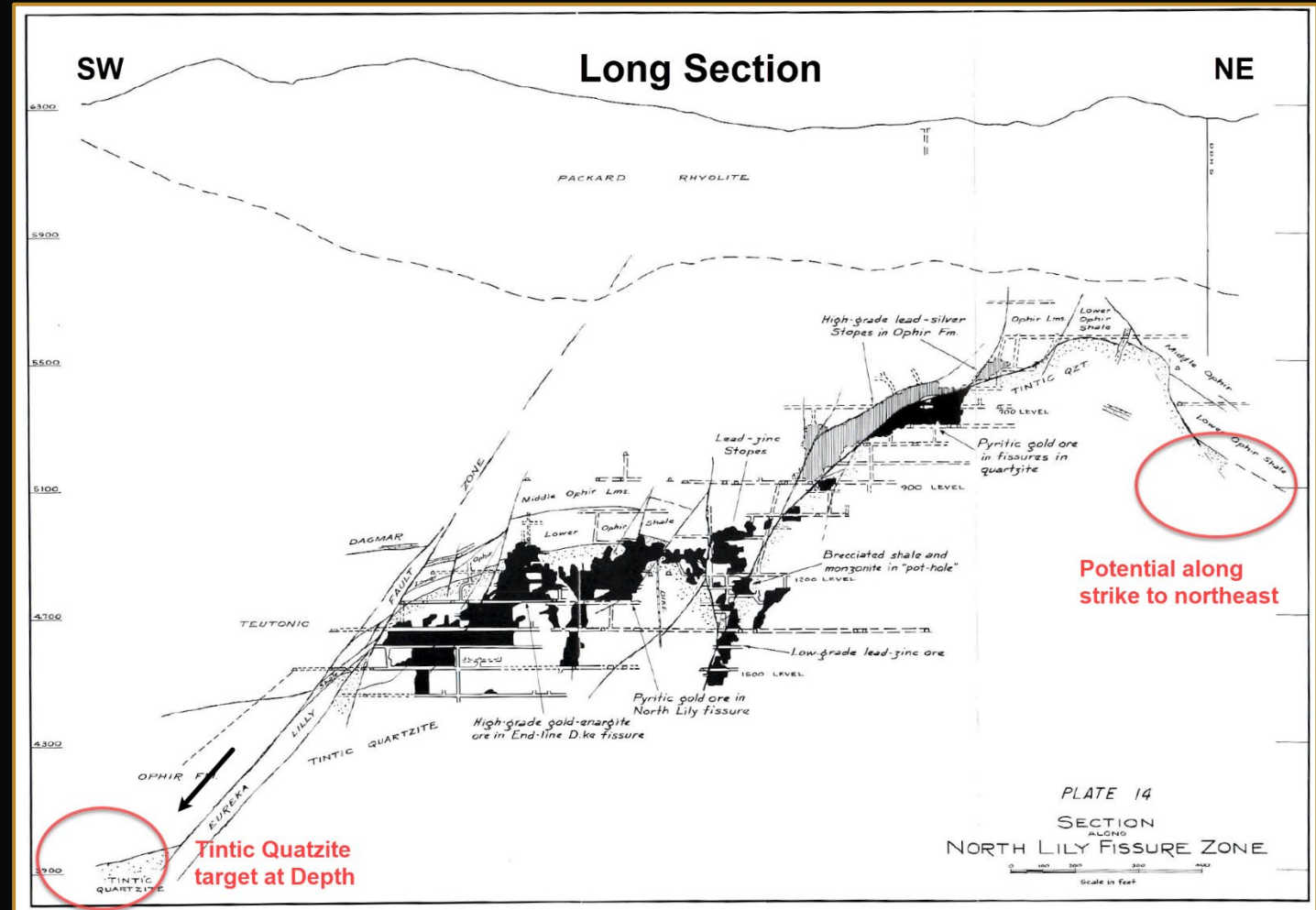

Ag-Pb-Zn OLD BURGIN MINE



- The Burgin mine hosts a significant Pb-Zn-Ag-Au replacement style deposit
- Mined by Kennecott until 1978, with the “Burgin Extension” discovered from drilling undertaken in 1980
- Preliminary Economic Assessment 2011 (included historic resource)

Historic Resource from Burgin 2011 PEA⁽¹⁾

Burgin Extension Resources – 2011 NI 43-101 PEA

Burgin Reported Resources										
Class	Cutoff oz AgEq/t	Tons	oz Ag/t	oz Ag	oz Au/t	oz Au	% Pb	lbs Pb	% Zn	lbs Zn
Indicated	5.0	920,000	7.28	6,694,000	0.025	23,000	9.27	170,461,000	3.45	63,497,000
Inferred	5.0	1,357,000	8.71	11,823,000	0.013	17,000	14.43	391,589,000	5.19	140,846,000

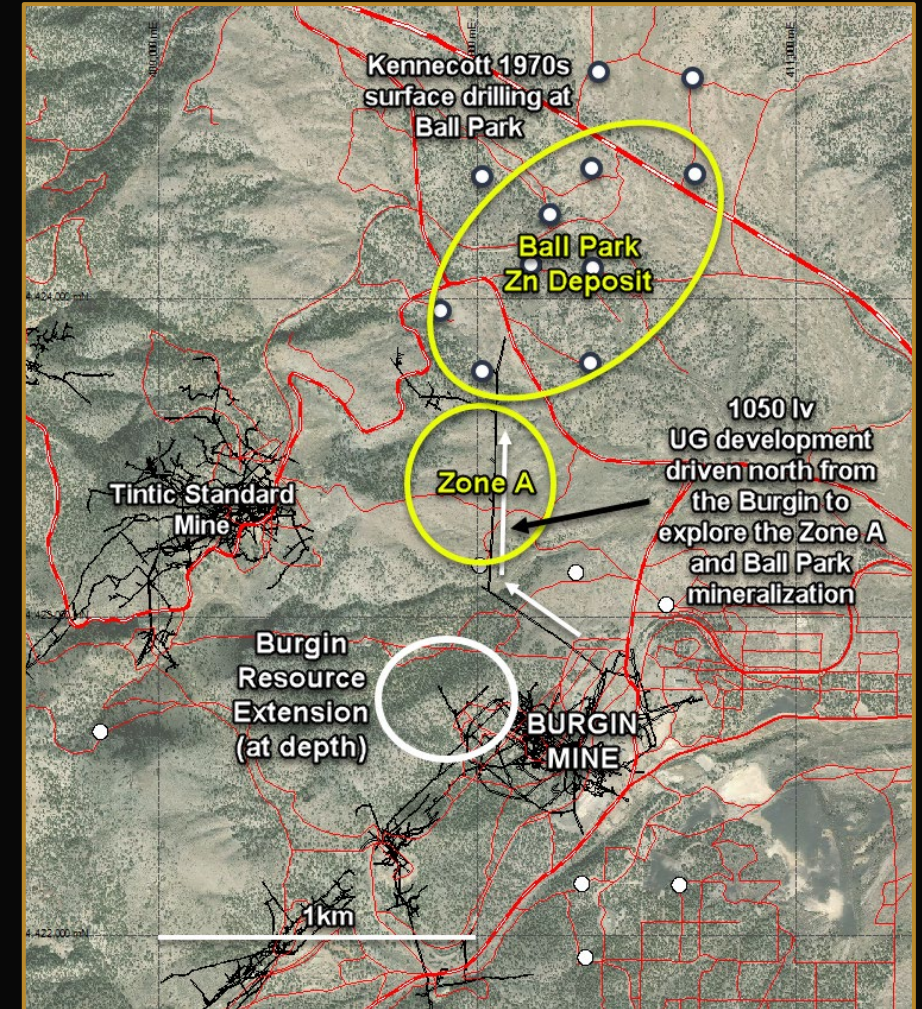

(1) Please see cautionary statement regarding historic resources.

BURGIN RESOURCE EXTENSION



Down plunge mineralization remains open at depth

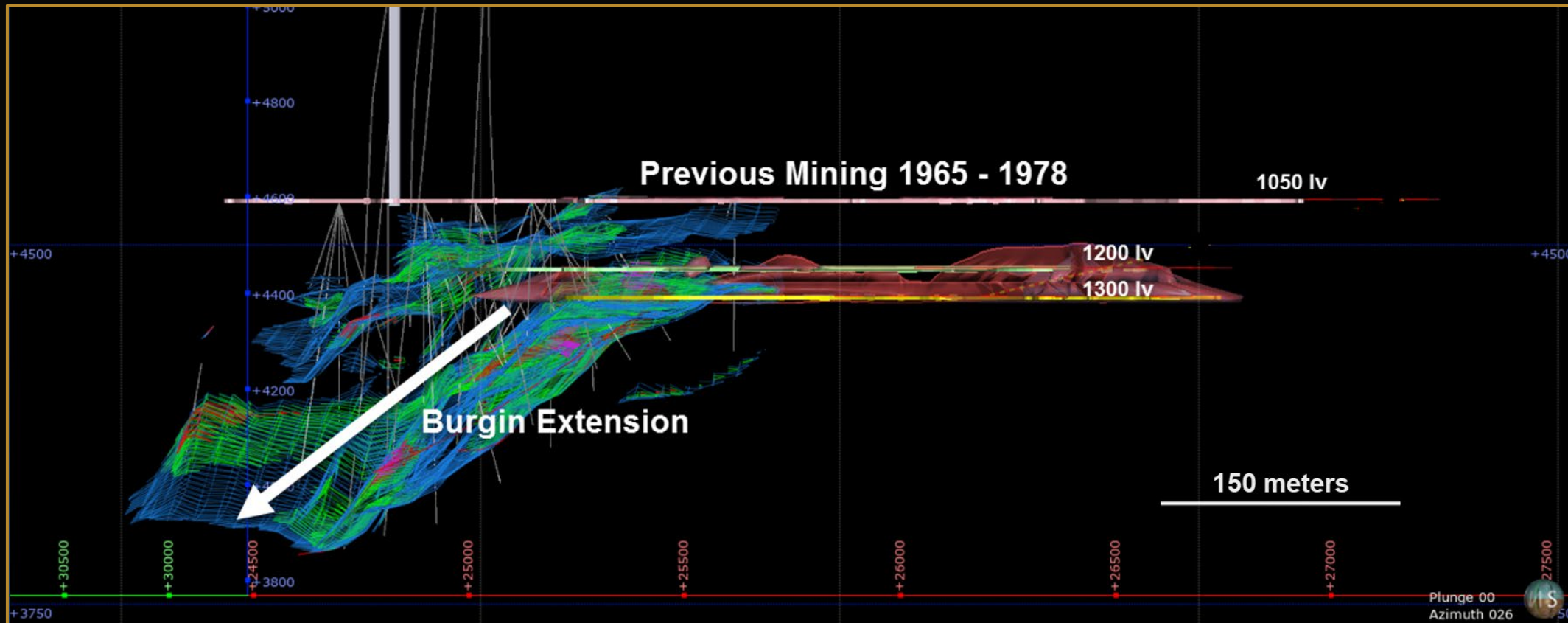

BURGIN BALL PARK OPPORTUNITY



- Ball Park target (Zn-Pb) is located 5000 ft. (1.5 km) north of the Burgin mine
- Kennecott surface drilling in 1970s intersected significant Zn-Pb mineralization at Ball Park
- During the 1970's Kennecott developed the 1050 level north of Burgin to explore this area, with underground drilling intersecting significant base and precious metals mineralization associated with the Tintic Thrust, in a similar structural setting to the Burgin deposit
- Two target areas: Zone A and 50-02

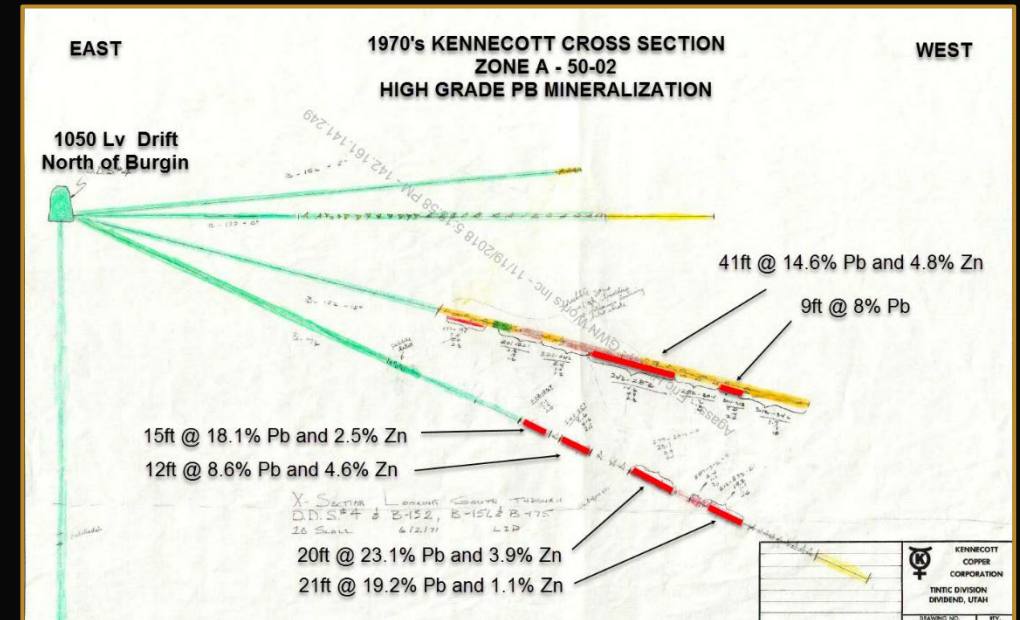

- Sub-horizontal mineralization, high grades, large tonnage
 - High grade Zn-Pb deposit with up to 65 ft. mineralized drill widths
- Avg grades of 2.7% Zn and 1.3% Pb, locally up to 8.6% Zn

Trixie 3D Model



- 6 historic levels of development, main shaft and ventilation shaft
- 610 stope that was mined in 2001 – 2002
- Flux Mining - each of the larger Kennecott stopes, 756 ore shoot and Survey Vein
- Historic ore panels are open at depth. Water table below the 1450L

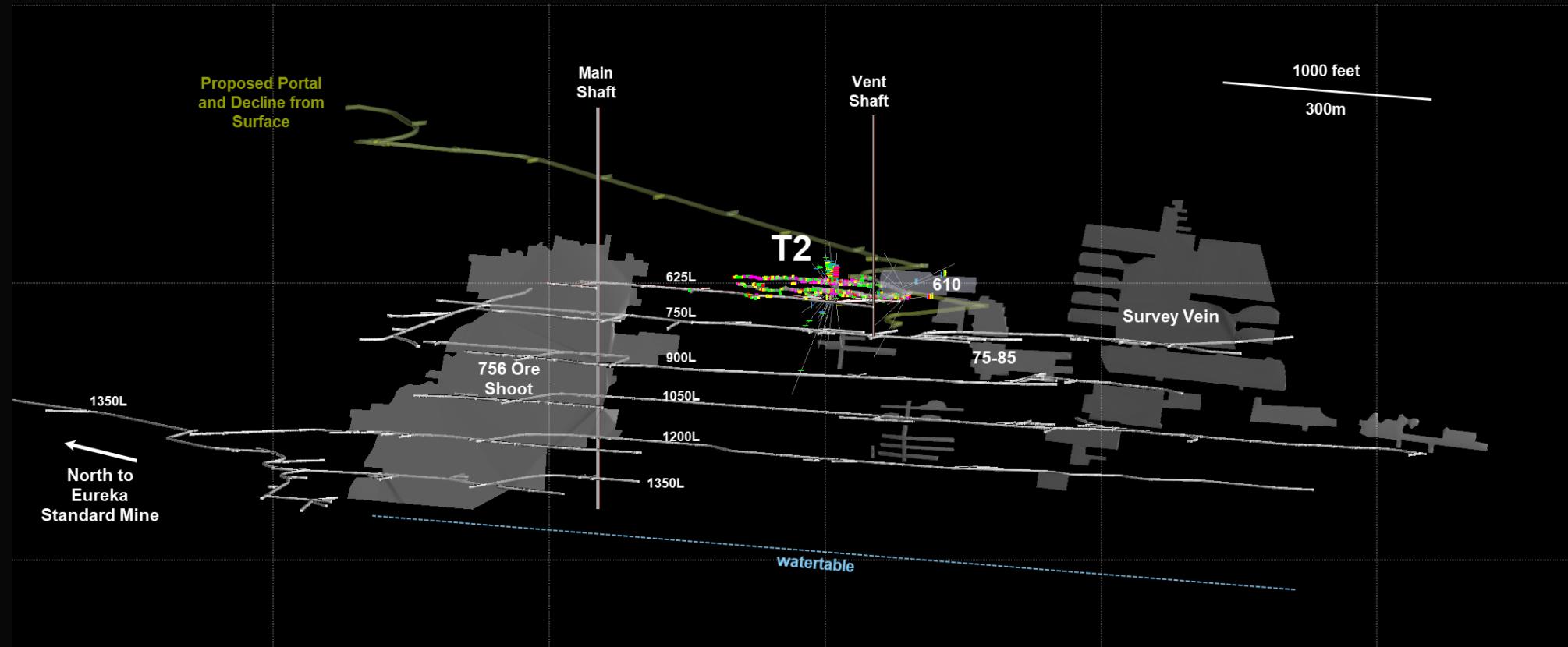

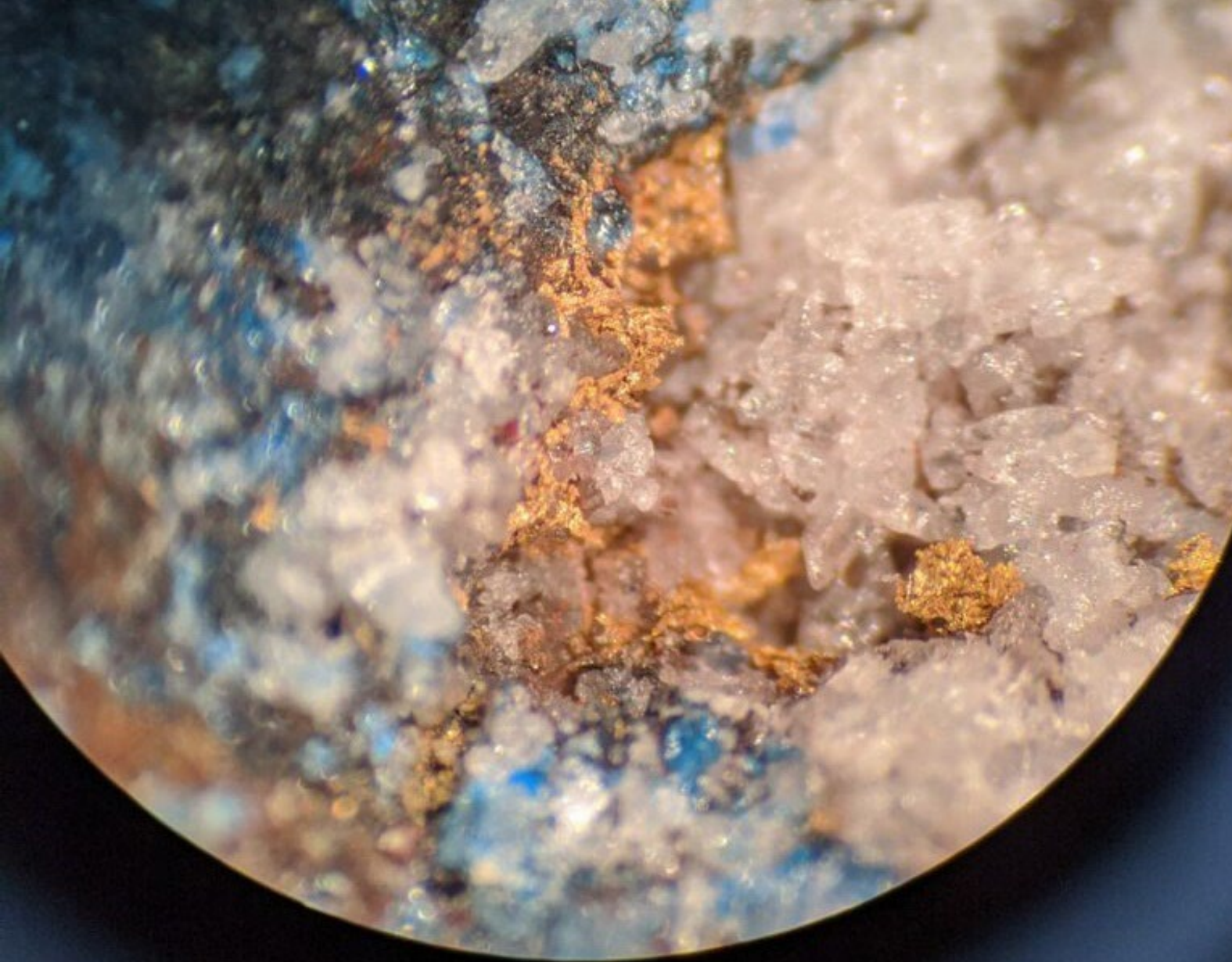

Thank You

www.osiskodev.com